

HYDRO

Version 4.0

User's Guide

**ATA Engineering, Inc.
11995 El Camino Real, Suite 200
San Diego, California 92130
858-480-2000**

© ATA Engineering, Inc., 2009

All rights reserved. No part of this publication may be reproduced or transmitted, in any form or by any means, without permission.

Restricted Rights Legend

Use, duplication, or disclosure of the technical data contained in this document by the Government is subject to restrictions as set forth in subdivision (c) (1) (ii) of the Rights in Technical Data and Computer Software clause at DFARS 52.227-7013, and/or in similar or successor clauses in the FAR, or the DOD or NASA FAR Supplement. Unpublished rights reserved under the Copyright Laws of the United States. Contractor/manufacturer is ATA Engineering, Inc., 11995 El Camino Real, San Diego, CA 92130.

ABSTRACT

HYDRO is a computer program that develops models of sloshing incompressible fluid in NASTRAN. The user prepares the fluid model in any preprocessor and writes it out as a NASTRAN deck. HYDRO reads this deck and prepares a series of two or more NASTRAN input decks that generate a model of the fluid. The model represents either fully enclosed fluids, or fluids with free surfaces. For fluids with free surfaces, the surfaces can move relative to inertial space or to any node on the structure. In either case, fluid slosh modes are calculated. A no-slosh option is also provided that correctly removes the sloshing weight of the fluid from the model. The no-slosh option can either be run in standard mode, where the fluid mass matrix is added to the structure before calculating modes, or in a “fast” mode, where the fluid mass is added after calculation of empty modes. In all cases, the fluid model is designed to be coupled with a NASTRAN structural model to calculate the coupled fluid/structural response. Applications include fuel and water storage tanks, rocket fuel tanks, and automotive and motorcycle fuel tanks.

TABLE OF CONTENTS

1. INTRODUCTION	1
2. THEORY	5
2.1. Fluid Equations of Motion	5
2.2. Area Matrices	10
2.3. Fluid Mass	12
2.4. Incompressibility	14
2.5. Free Surface Stiffness.....	15
2.6. Relative Free Surface	17
2.7. Fluid Superelement Model	17
2.8. Coupling the Fluid and Structural Models	19
2.9. Fast Solution Method	19
3. OPERATION PROCEDURES.....	22
3.1. Develop Hydroelastic Model.....	24
3.2. HYDRO “Prep” Run	27
3.3. FLK – Generate Fluid Inertance (Stiffness) Matrix	31
3.4. FLM – Generate Fluid Mass Matrix.....	32
3.5. FSK – Generate Free Surface Stiffness Matrix	33
3.6. HYDRO “MPC” Run	34
3.7. SUP – Generate Hydroelastic Model Superelement.....	34
3.8. Coupling of Fluid Superelement to Structural Models.....	35
3.9. Coupling of Fluid to Structural Models Using "FAST" Option.....	36
4. EXAMPLE PROBLEMS	38
4.1. Fluid Hemisphere and Cylindrical Tank	38
4.1.1. I-deas Hydroelastic Finite Element Model.....	39
4.1.2. HYDRO “Prep” Run	41
4.1.3. FLK - Fluid Stiffness (Inertance) Matrix	51
4.1.4. FLM - Fluid Mass Matrix Run.....	52
4.1.5. FSK - Free Surface Stiffness Matrix Run.....	56
4.1.6. HYDRO “MPC” Run	56
4.1.7. SUP - Fluid Superelement Run	57
4.1.8. Coupled Hydroelastic Model.....	60
4.2. Motorcycle Tank Stress Model	66
4.2.1. I-deas Hydroelastic Finite Element Model.....	67
4.2.2. HYDRO “Prep” Run	68
4.2.3. FLK - Fluid Stiffness (Inertance) Matrix	70
4.2.4. FLM - Fluid Mass Matrix Run.....	71
4.2.5. Coupled Hydroelastic Model.....	71

5. ACCURACY CHECKS	77
5.1. Fluid Mesh Refinement	77
5.2. Coordinate Systems	80
5.3. Coincident Node Check.....	81
5.4. Element Quality Checks	81
5.5. Shell Element Normals.....	82
5.6. Fluid Mass Check.....	83
REFERENCES.....	85
Appendix A New Features and Enhancements in HYDRO Version 2.....	A-1
Appendix B New Features and Enhancements in HYDRO Version 3.....	B-1
Appendix C New Features and Enhancements in HYDRO Version 4.....	C-1

LIST OF TABLES

Table 2-1. Analogy between fluid and heat transfer variables.....	8
Table 3-1. Summary of input for the HYDRO “Prep” run.	29
Table 4-1. Inputs to HYDRO run for hemisphere example.	42
Table 4-2. Comparison of slosh mode frequencies.	60
Table 4-3. Data written to CPL runs for different options with standard superelements.....	60
Table 4-4. Data written to CPL runs for different options with external superelements.	61
Table 4-5. Comparison of structural frequencies for different fluid options.	64
Table 4-6. Inputs to HYDRO run for motorcycle tank example.....	69
Table 4-7. Frequencies of 250 tank modes without fluid.	74
Table 4-8. Frequencies of tank modes below 250 Hz with fluid mass.	75
Table 5-1. Slosh mode frequencies for the Titan IV Centaur modal survey test configuration for several fluid mesh refinements.....	79
Table 5-2. Slosh mode frequencies for the hemisphere with coarse and fine meshes.	80

LIST OF FIGURES

Figure 1-1. Hydroelastic models are used to model fluid in thin-walled tanks.	1
Figure 1-2. A hydroelastic model is developed in a three-step process.	3
Figure 2-1. Fluid is modeled with linear solid elements.	7
Figure 2-2. The finite element model of an incompressible fluid can be mathematically reduced to the boundary nodes with no loss of accuracy.	9
Figure 2-3. A column of the area matrix contains the structural forces caused by a unit pressure at a fluid boundary node.	11
Figure 2-4. Lateral and axial slosh modes occur when the fluid has a free surface and is in a gravity field.	15
Figure 2-5. Large numbers of axial and lateral slosh modes will exist when the fluid has a free surface.	16
Figure 3-1. The coupled hydroelastic model is formed using NASTRAN and a special Fortran program called HYDRO.	22
Figure 3-2. There will be three coincident nodes at the intersection of the fluid, wetted structure, and free surface.	25
Figure 3-3. The hydroelastic finite element model will include solid elements for the fluid and shell elements for the wetted structure and free surface (exploded view).	26
Figure 3-4. HYDRO graphical user interface.	31
Figure 3-5. Bulk data added to standard modes run to perform “fast” coupled fluid solution.	37
Figure 4-1. The example problem includes a hemisphere of water in a thin-walled tank.	38
Figure 4-2. A cross section of the fluid was meshed.	39
Figure 4-3. The fluid model cross section was revolved to create the hydroelastic finite element model.	40
Figure 4-4. The orientation of the wetted structure and free surface shells were checked to verify that their orientation was uniformly outward.	41
Figure 4-5. HYDRO input for fluid hemisphere example with ENCLOSED option.	43
Figure 4-6. HYDRO input for fluid hemisphere example with NO_SLOSH_FAST option.	43
Figure 4-7. HYDRO input for fluid hemisphere example with FIXED option.	44
Figure 4-8. HYDRO input for fluid hemisphere example with NO_SLOSH_STD option.	44
Figure 4-9. HYDRO input for fluid hemisphere example with RELATIVE option.	45
Figure 4-10. HYDRO GUI input for fluid hemisphere example with ENCLOSED option.	46
Figure 4-11. HYDRO GUI input for fluid hemisphere example with NO_SLOSH_FAST option.	47
Figure 4-12. HYDRO GUI input for fluid hemisphere example with FIXED option.	48
Figure 4-13. HYDRO GUI input for fluid hemisphere example with NO_SLOSH_STD option.	49
Figure 4-14. HYDRO GUI input for fluid hemisphere example with RELATIVE option.	50
Figure 4-15. NASTRAN .f06 file output for FLK run with ENCLOSED, FIXED, or RELATIVE options.	51
Figure 4-16. NASTRAN .f06 file output for FLK run with NO_SLOSH_STD or NO_SLOSH_FAST options.	52
Figure 4-17. Grid Point Weight Generator Output for ENCLOSED, FIXED, and RELATIVE options.	53
Figure 4-18. Grid Point Weight Generator output for NO_SLOSH_STD option.	54
Figure 4-19. Mass Property Output for NO_SLOSH_FAST Option.	54
Figure 4-20. A single mass matrix is written to the database for the NO_SLOSH_STD and ENCLOSED options.	55
Figure 4-21. Three partitions of the mass matrix are written to the database for the FIXED and RELATIVE options.	55
Figure 4-22. The UTOPG pressure recovery matrix is written to the database if any pressure recovery grids were selected.	55
Figure 4-23. The FSK run stores the FKGGDMIG matrix in the database.	56

Figure 4-24. Modal Effective Mass Fractions for First 50 Modes of Hemisphere Example	59
Figure 4-25. Coupled fluid-structure template written by HYDRO for the hemisphere example.	63
Figure 4-26. External DMIGOP2 SE coupled fluid-structure template.....	65
Figure 4-27. DMIG Only coupled fluid-structure template.....	66
Figure 4-28. Outer shell of motorcycle tank example.....	67
Figure 4-29. Fluid surface elements (wetted tank and free surface).	67
Figure 4-30. Fluid surface elements (wetted tank and free surface).	68
Figure 4-31. HYDRO input for motorcycle tank example.	69
Figure 4-32. HYDRO GUI input for fluid hemisphere example with ENCLOSED option.	70
Figure 4-33. NASTRAN .f06 file output for motorcycle tank FLK run.....	71
Figure 4-34. Mass property output for motorcycle tank example.....	71
Figure 4-35. Structure coupling run written by HYDRO.	72
Figure 4-36. Structure coupling run after editing.	73
Figure 4-37. Fluid mass properties from structure coupling run.	75
Figure 4-38. First flexible coupled mode for motorcycle tank.	76
Figure 4-39. First flexible coupled mode for motorcycle tank.	76
Figure 5-1. Titan/Centaur modal survey configuration.	78
Figure 5-2. At least sixteen elements across the free surface were required to obtain 5% accuracy on the third lateral slosh mode for the Titan IV Centaur modal survey test configuration.	78
Figure 5-3. Fine mesh representation of hemisphere example problem.	79
Figure 5-4. Free edge check can identify errors in the HYDRO FEM.	82
Figure 5-5. Element normal vector display is selected on the View Options form in FEMAP.	83
Figure 5-5. External superelement options.	C-2

Abbreviations

ATA	ATA Engineering, Inc.
DOF	Degrees of freedom
DMAP	Direct matrix abstraction program
GUI	Graphical user interface
HFEM	Hydroelastic finite element model
HYDRO	Hydroelastic modeling and analysis procedure
I-deas	Integrated Design Engineering Analysis System
NASTRAN	NASA Structural Analysis Program
SOL	NASTRAN solution sequence (rigid format)

Scalar Variables

β	Bulk Modulus
g	Gravity
ρ	Density

Matrices

A	Area
F	Force
G	Transformation
K	Stiffness
M	Mass
p	Pressure
u	Displacement
\ddot{u}	Acceleration
ϕ	Normal mode shapes
Φ	Unit rigid body mode shapes

Superscripts

<i>f</i>	Fluid
<i>n</i>	Normal displacements at the free surface
<i>s</i>	Structure

Subscripts

<i>a</i>	A-set (analysis DOF)
<i>g</i>	G-set (all DOF)
<i>m</i>	M-set (MPC)
<i>n</i>	Normal DOF (free surface)
<i>o</i>	O-set (omitted DOF)
<i>r</i>	R-set (SUPPORT DOF)

1. INTRODUCTION

HYDRO is a procedure for developing hydroelastic finite element models of incompressible fluids in NASTRAN¹. Typical hydroelastic models include liquid fuel rockets, fuel storage tanks, and other fluid-filled tanks, as shown in Figure 1-1.

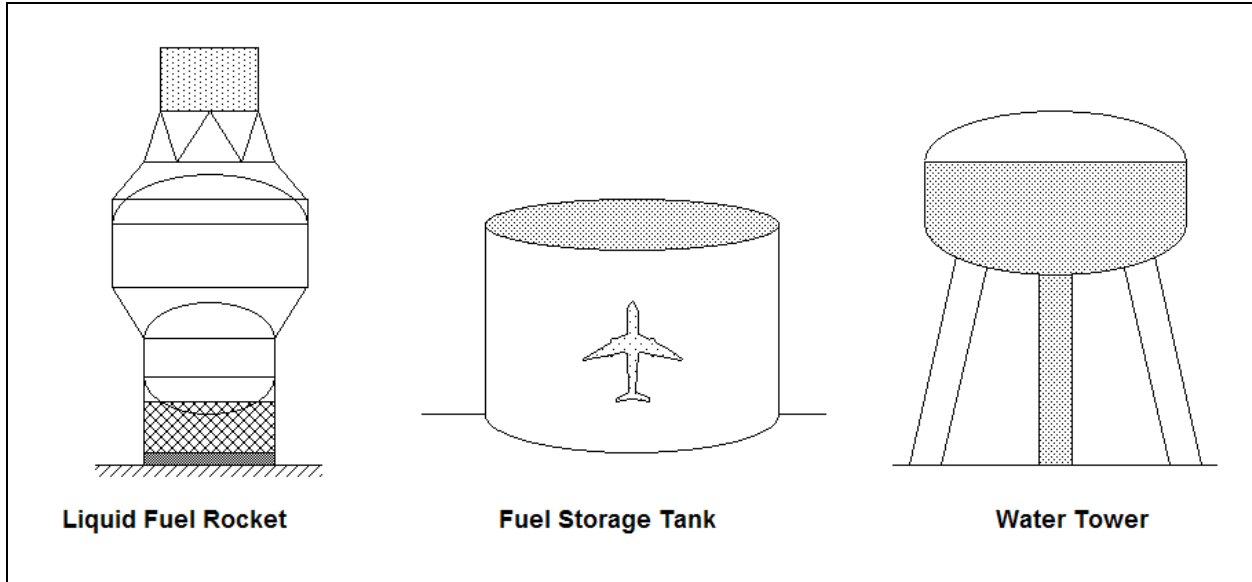

Figure 1-1. Hydroelastic models are used to model fluid in thin-walled tanks.

HYDRO was originally developed for modeling the Titan IV/Centaur upper stage and has since been used on a large number of different rockets as well as motorcycle fuel tanks. HYDRO offers many advantages for static, modal, and transient analysis of hydroelastic models when compared with other options in NASTRAN:

- The HYDRO mathematical formulation produces symmetric matrices instead of unsymmetric matrices developed by many methods including the NASTRAN axisymmetric approach.
- The HYDRO solution is compatible with standard symmetric matrix multiplication, decomposition, forward-backward substitution, and real eigensolver methods. Important postprocessing operations (modal effective mass, rigid body mass from rigid body modes, effective rigid body mass, etc.) can be readily performed using the symmetric matrices.

¹ Both MSC and NX Nastran are supported.

- Mass of the elements connected to the axis of an axisymmetric model is correctly included by the HYDRO procedure, unlike the limitation of the NASTRAN axisymmetric method.
- The geometry of the fluid is arbitrary in HYDRO. The geometry is not limited to axisymmetric systems. Annular fluid volumes and more complex shapes can be easily and accurately processed.
- The coupled hydroelastic model may be restrained or free-free. HYDRO does not introduce artificial grounding that would prevent rigid body motion.
- HYDRO is compatible with NASTRAN superelement technology. The fluid superelement may be introduced at any level in the superelement tree. Both standard bulk data and external superelements are supported.
- Multiple fluid models can be included in a single model. Each fluid model is represented by a superelement. There is no limit on the number of fluid superelements that can be included in a model².
- Fluid incompressibility is explicitly enforced by a multipoint constraint (MPC) equation. No compressibility assumptions or approximations are required.
- The fluid model can include a free surface or can be completely enclosed by a wetted surface. If the fluid model has a free surface, slosh modes are calculated to identify slosh frequencies and effective mass, or an alternative no-slosh model can be used.
- The fluid free surface reference plane can be fixed or can be relative to a local acceleration vector.
- Unimportant slosh modes can be easily eliminated from the fluid superelement to improve efficiency and avoid large numbers of unneeded system modes.
- The hydroelastic mode shapes can be easily plotted using I-deas, Femap, or any other NASTRAN postprocessor. A special “display” model can plot the modes of both the structure and free surface.

² The “fast” no-slosh option does not use superelements and is currently limited to a single fluid model, though this can span multiple tanks.

- HYDRO has been proven to provide accurate results if the fluid element mesh is sufficiently refined.
- HYDRO includes a “fast” option that uses the empty modes of the structure to reduce the mass matrix, allowing the user to solve very large fluid structure interaction problems.
- While HYDRO does require the execution of a sequence of NASTRAN runs, this process is automated using an intuitive graphical user interface (GUI).

The overall procedure for developing and using a hydroelastic model is a three-step process, as shown in Figure 1-2. The first step is to create the hydroelastic finite element model (HFEM). The HFEM includes solid elements for the fluid and shell elements representing the wetted structure and fluid free surface. There are several requirements for the HFEM that must be satisfied to provide correct fluid properties and to ensure compatibility between the fluid and structural models.

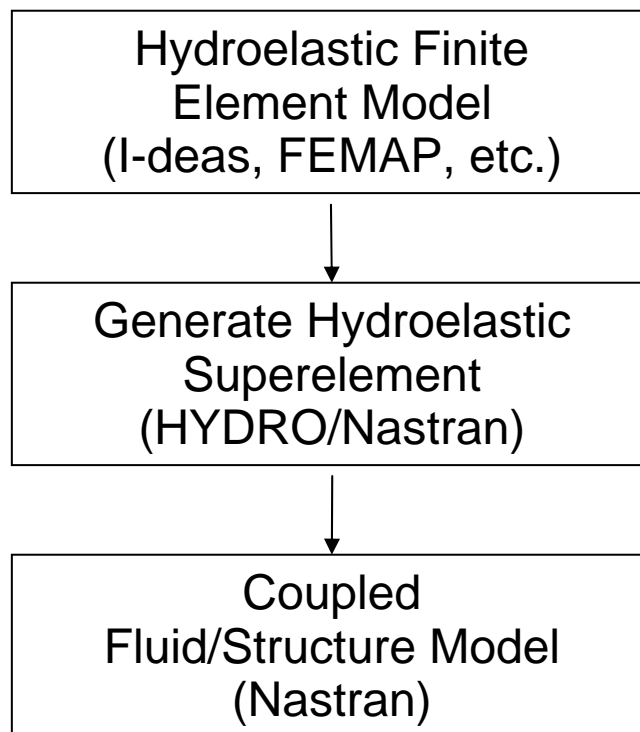

Figure 1-2. A hydroelastic model is developed in a three-step process.

The second step in developing a hydroelastic model is to create the fluid superelement. This is done using NASTRAN³ and the HYDRO program. HYDRO reads the FEM in NASTRAN

³ Both MSC and NX Nastran are supported.

format and writes a series of two or more NASTRAN input decks. The output from this series of runs is either a NASTRAN superelement of the fluid model or matrices that can be used to represent the fluid mass.

The final step in the HYDRO procedure is to couple the fluid superelement to the structural model. This step is performed using standard superelement methods, or through the use of a DMAP alter, if using the "fast" method. If desired, multiple fluid components can be defined and assembled into a single model.

The theory for the hydroelastic analysis of incompressible fluids is presented in Chapter 2. This chapter describes the derivation of the fluid equations of motion and the procedures to couple the fluid model to the structural model. Additional references are included in Appendix A.

Chapter 3 describes the implementation of the HYDRO procedures, with all steps described.

Two complete sample problems are presented in Chapter 4. This chapter illustrates the development of the hydroelastic finite element model, execution of the HYDRO program, running the NASTRAN hydroelastic runs, and coupling the fluid superelement to a structural model.

Chapters 5 and 6 describe accuracy checks and error messages. The accuracy checks should be performed by the user to verify that the fluid superelement was properly defined and that all operations were performed satisfactorily. The error messages provide more-complete descriptions of errors from HYDRO or NASTRAN, along with suggestions for correcting the errors.

2. **THEORY**

The fundamental assumption for a hydroelastic model is that the fluid dynamics can be represented by potential flow. This is valid for a fluid which is inviscid (viscosity effects negligible), irrotational (zero vorticity), and undergoing small amplitude oscillations (linear small motion theory).

The fluid degrees of freedom (DOF) are pressures. Since the structure is represented by displacement DOF (translations and rotations at the grid points), special techniques are needed to couple the fluid pressure model to the structural displacement model. This is accomplished by “area matrices” that convert fluid pressures to corresponding structural forces.

If the fluid is not completely contained by a structure, the fluid will have a free surface. For this configuration, the fluid will have “slosh” modes that can be extremely important for both the fluid dynamic characteristics and the coupled fluid/structure modes.

For a wide range of problems, the compressibility of the fluid is negligible in comparison to the structural flexibility. For these problems, the fluid can be assumed to be incompressible. This greatly simplifies the fluid equations of motion and also results in a symmetric formulation for the coupled fluid/structure system.

The final result of a hydroelastic model depends on the option chosen. For a fully enclosed fluid or a fluid using the no-slosh option, it is a fully coupled mass matrix; for a fluid with a sloshing free surface it is a Craig-Bampton [1] superelement that defines the mass and dynamic characteristics of the fluid; and for the "fast" no-slosh option it is two matrices that can be used to represent the fluid mass matrix in the coupled run. A multipoint constraint equation is also defined to enforce the incompressibility relationship for all but the no-slosh options.

2.1. **Fluid Equations of Motion**

The fluid equations of motion presented in this section follow the derivation presented by Herting, Hoesly, and Herendeen in [2]. The equations of motion for an irrotational fluid can be developed in the form of energy integrals using principles of variational calculus [3]:

$$\delta \left[\int_V \left(\frac{1}{2\beta} \dot{p}^2 + \frac{1}{2\rho} \nabla p \cdot \nabla p \right) dV \right] - \int_S \delta p \left(\frac{1}{\rho} \nabla p \right) d\bar{S} \quad (1)$$

where:

p	= pressure
\dot{p}	= time derivative of pressure
β	= bulk modulus
ρ	= mass density
V	= volume
$d\vec{S}$	= incremental surface vector (outward)
∇	= vector gradient operator
δ	= variational operator

Equation (1) can be greatly simplified if the fluid is assumed to be incompressible. This is an accurate assumption if the frequencies of the fluid acoustic modes are much greater than the frequencies of the fluid/structure modes of interest. For an incompressible fluid, the bulk modulus is assumed to be infinite, and the \dot{p}^2 term in (1) is zero. On the exterior surface of the fluid, the pressure gradient may be replaced with the acceleration vector, \vec{u} , using the momentum equation

$$\nabla p = -\rho\vec{u} \quad (2)$$

Equation (1) can be rewritten for an incompressible fluid using (2) and eliminating the \dot{p}^2 term:

$$\delta \left[\int_v \left(\frac{1}{2\rho} \nabla p \cdot \nabla p \right) dV \right] - \int_s \delta p \vec{u} \cdot d\vec{S} = 0 \quad (3)$$

or

$$\delta U + \delta W = 0 \quad (4)$$

The continuum equation (3) can be discretized using the finite element method. The fluid volume is divided into a number of solid finite elements. At each grid point, there is one DOF representing the pressure at that location in the fluid. Typically, linear finite elements are used which assume linear variation of pressure between grid points. Sufficient elements must be defined such that linear pressure variation accurately represents the fluid behavior. A typical fluid finite element model is shown in Figure 2-1.

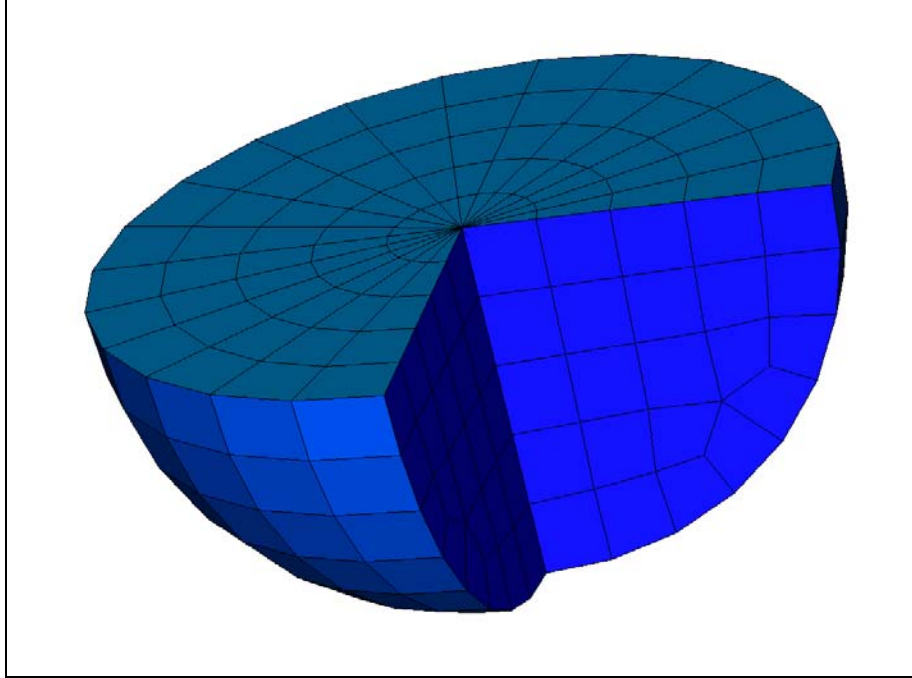

Figure 2-1. Fluid is modeled with linear solid elements.

The continuum equation (3) can be written in matrix form for a finite element model:

$$[K^f]\{p\} + [B]\{\ddot{u}\} = 0 \quad (5)$$

where

$$B_{ij} = \frac{\partial}{\partial p_i \partial u_{j_s}} \int p \bar{u} \cdot d\bar{S} \quad (6)$$

$$K_{ij}^f = \frac{\partial}{\partial p_i \partial p_{j_v}} \int \frac{1}{2\rho} \nabla p \cdot \nabla p dV \quad (7)$$

There is an analogy between the incompressible fluid equations of motion and those for heat transfer analysis as shown by Coppolino [4]. The analogy between the fluid and heat transfer is summarized in Table 2-1.

Table 2-1. Analogy between fluid and heat transfer variables.

FLUID MODEL		HEAT TRANSFER MODEL	
Variable	Symbol	Variable	Symbol
Pressure	p	Temperature	T
Outward normal acceleration	\vec{u}	Outward normal flux/area	f_n inverse
Mass density	ρ	Inverse thermal conductivity	$1/K_t$
Incompressible	$\beta = \infty$	No heat capacity	$C_p = 0$

Therefore, a fluid model can be defined using standard heat transfer modeling and analysis procedures with the appropriate analogy for the material properties.

The fluid model can be mathematically reduced to those grid points that are on the exterior of the fluid, as shown in Figure 2-2.

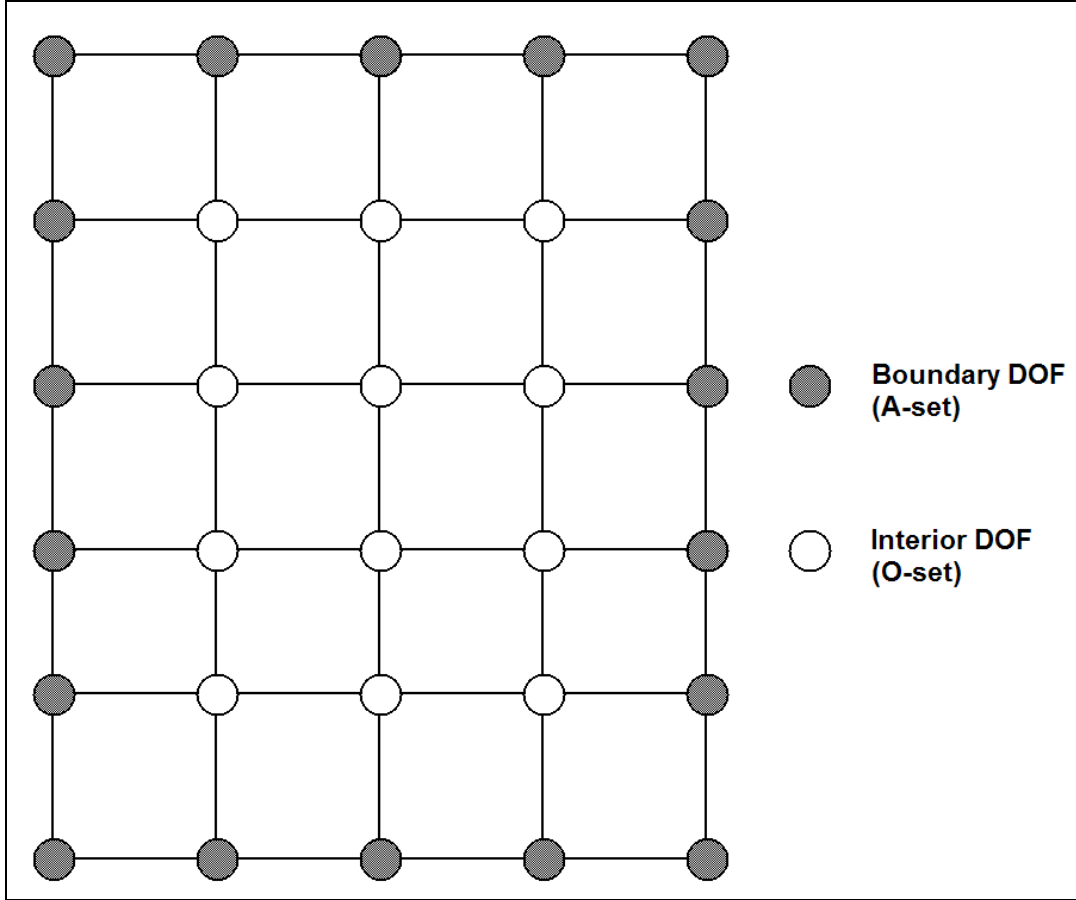

Figure 2-2. The finite element model of an incompressible fluid can be mathematically reduced to the boundary nodes with no loss of accuracy.

The reduction from all pressure DOF to the exterior DOF is performed using the same equations as Guyan reduction [5] for a structural model. First, partition the fluid stiffness matrix into interior and boundary terms:

$$[K^f] = \begin{bmatrix} K_{oo}^f & K_{oa}^f \\ K_{ao}^f & \bar{K}_{aa}^f \end{bmatrix} \quad (8)$$

Calculate unit pressure shapes:

$$[G_{oa}^f] = -[K_{oo}^f]^{-1}[K_{oa}^f] \quad (9)$$

Form the reduced fluid stiffness matrix:

$$[K_{aa}^f] = -[\bar{K}_{aa}^f] + [K_{ao}^f][G_{oa}^f] \quad (10)$$

For an incompressible fluid, the reduction is **exact**. The reduction to the fluid exterior DOF provides a substantial decrease in the fluid matrix size and the analysis costs for developing the fluid model.

HYDRO provides two options for representing a fluid free surface. In the standard option, the fluid free surface mass is retained in order to calculate slosh modes, and the boundary of the fluid therefore consists of both the wetted structural surface and the free surface. The second case is a no-slosh option, where the slosh modes are not explicitly calculated, though the sloshing mass is correctly removed from the problem. In this case, the fluid free surface pressure DOF are set to zero (SPCed) and are not included in the A-set. The no-slosh solution also has a “fast” option where the fluid mass matrix is never explicitly calculated. This is described in Section 2.9.

2.2. **Area Matrices**

The fluid model is represented by pressure degrees of freedom. However, a structural model is represented by displacements (translations and rotations) at the structural grid points. Special procedures are needed to connect the fluid and structure models since they have different types of DOF.

The pressure and displacement DOF are coupled using “area matrices.” An area matrix converts the pressure at a fluid DOF to an equivalent set of forces on the structural DOF, as shown in Figure 2-3.

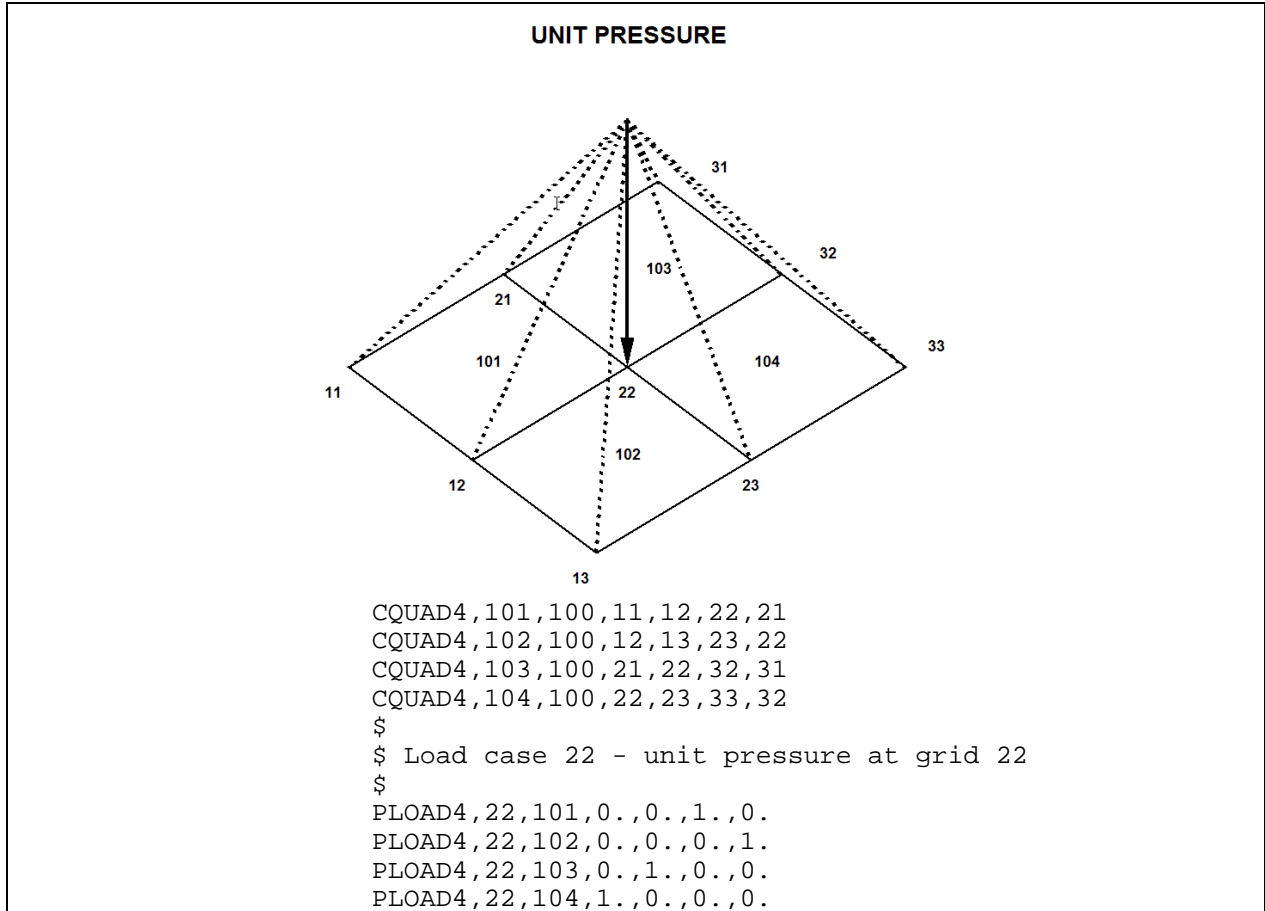

Figure 2-3. A column of the area matrix contains the structural forces caused by a unit pressure at a fluid boundary node.

There will be one column in the area matrix corresponding to each exterior fluid DOF. The structural forces exerted by the fluid on the structure can be written as:

$$\{F_g\} = [A_{ga}] \{p_a\} \tag{11}$$

where

$$A_{ij} = \frac{\partial}{\partial u_i \partial p_j} \int p \vec{u} \cdot d\vec{S} \tag{12}$$

Comparing (6) and (13), it can be seen that:

$$[A] = [B]^T \tag{13}$$

The area matrices are generated by the HYDRO procedure using PLOAD4 cards. For each exterior fluid DOF, the appropriate wetted structure and free surface elements are identified. A PLOAD4 card is written for each element with a unit pressure at the fluid node and zero pressure at all other nodes. This process defines linearly varying pressure fields that are compatible with the linear fluid elements. Typical PLOAD4 statements are shown in Figure 2-3.

2.3. **Fluid Mass**

After generating the area matrices, the fluid stiffness matrix generated as described in Section 2.1 can be converted to an equivalent mass matrix at the wetted structure and free surface degrees of freedom. The equation of motion for the structure as forced by the fluid pressures can be written as:

$$[M_{gg}^s] \{\ddot{u}_g\} + [K_{gg}^s] \{u_g\} - [A_{ga}] \{p_a\} = \{0\} \quad (14)$$

The pressure in (14) can be obtained by inserting (13) into (5) and solving for p_a :

$$[K_{aa}^f] \{p_a\} + [A_{ga}]^T \{\ddot{u}_g\} = 0 \quad (15)$$

$$\{p_a\} = -[K_{aa}^f]^{-1} [A_{ga}]^T \{\ddot{u}_g\} \quad (16)$$

Unfortunately, in the standard free-surface option, $[K_{aa}^f]$ is singular and cannot be directly inverted. $[K_{aa}^f]$ contains one rigid body mode corresponding to uniform exterior pressure causing no potential in the fluid. This situation is similar to uniform displacements in a structure causing no internal strain energy. When using either of the no-slosh options, the pressure DOF on the entire free surface of the fluid are restrained, so this is not an issue.

To invert $[K_{aa}^f]$, one pressure DOF must be selected as a reference, and all other fluid DOF are expressed relative to the reference grid [4]. Next rewrite (16) into reference and complementary partitions as follows:

$$\begin{bmatrix} K_{rr}^f & K_{rl}^f \\ K_{lr}^f & K_{ll}^f \end{bmatrix} \begin{Bmatrix} p_r \\ p_l \end{Bmatrix} = - \begin{bmatrix} A_{gr}^T \\ A_{gl}^T \end{bmatrix} \{\ddot{u}_g\} \quad (17)$$

The reference pressure p_r can be subtracted from the pressure term in (17). This is equivalent to subtracting a rigid body displacement shape from a set of displacements without changing the structural strain energy.

$$\begin{bmatrix} K_{rr}^f & K_{rl}^f \\ K_{lr}^f & K_{ll}^f \end{bmatrix} \begin{Bmatrix} 0 \\ p_l \end{Bmatrix} = - \begin{bmatrix} A_{gr}^T \\ A_{gl}^T \end{bmatrix} \{\ddot{u}_g\} \quad (18)$$

The upper and lower partitions of (18) can be written as:

$$\begin{Bmatrix} K_{rl}^f \\ p_l \end{Bmatrix} = -[A_{gr}]^T \{\ddot{u}_g\} \quad (19)$$

$$\begin{Bmatrix} K_{ll}^f \\ p_l \end{Bmatrix} = -[A_{gl}]^T \{\ddot{u}_g\} \quad (20)$$

And the lower partition (20) can be solved for pressure as:

$$\begin{Bmatrix} p_l \end{Bmatrix} = -[K_{ll}^f]^{-1} [A_{gl}]^T \{\ddot{u}_g\} \quad (21)$$

The complete pressure vector (relative to the reference pressure) is:

$$\begin{Bmatrix} p_a \\ p_l \end{Bmatrix} = \begin{Bmatrix} 0 \\ p_l \end{Bmatrix} \quad (22)$$

Next, (22) can be substituted into (14):

$$[M_{gg}^s] \{\ddot{u}_g\} + [K_{gg}^s] \{u_g\} - [A_{gr} \quad A_{gl}] \begin{Bmatrix} 0 \\ p_l \end{Bmatrix} = \{0\} \quad (23)$$

Or, this can be expressed as:

$$[M_{gg}^s] \{\ddot{u}_g\} + [K_{gg}^s] \{u_g\} - [A_{gl}] \begin{Bmatrix} p_l \end{Bmatrix} = \{0\} \quad (24)$$

Equation (21) can be substituted into (24):

$$\left([M_{gg}^s] + [A_{gl}] [K_{ll}^f]^{-1} [A_{gl}]^T \right) \{\ddot{u}_g\} + [K_{gg}^s] \{u_g\} = \{0\} \quad (25)$$

or

$$\left([M_{gg}^s] + [M_{gg}^f] \right) \{ \ddot{u}_g \} + [K_{gg}^s] \{ u_g \} = \{ 0 \} \quad (26)$$

where

$$[M_{gg}^f] = [A_{gl}] [K_{ll}^f]^{-1} [A_{gl}]^T \quad (27)$$

M_{gg}^f represents the fluid mass transformed to the wetted structure and free surface degrees of freedom. Note that there is no fluid stiffness term in (26). This is correct since fluid has no stiffness.

In the case of a “no-slosh” surface, the fluid stiffness matrix $[K_{aa}^f]$ is not singular and no R-set is introduced into the problem. Otherwise, the calculation of the fluid mass is identical. In the “no-slosh” case, the fluid mass perpendicular to the surface will be equal to the full fluid mass. However, in the plane of the surface, the “no-slosh” fluid mass does not include the lateral mass of the fluid slosh modes. Since the fluid slosh modes are almost always at a much lower frequency than the structural modes, the “no-slosh” fluid surface option provides an excellent approximation of the effect of the fluid on the structure without introducing a large number of slosh modes to the problem. This can be used to simplify the problem.

In the "fast" version of the no-slosh fluid surface, the mass matrix is never calculated. Instead, the $[K_{ll}^f]^{-1}$ and $[A_{gl}]$ matrices are output and read directly into the coupled fluid/structure solution where they are used to construct a mass matrix in modal rather than physical coordinates.

2.4. **Incompressibility**

The fluid mass matrix was obtained using the lower partition of (18). An important additional result is obtained from the upper partition of (18). Inserting (21) into (19) results in the following expression:

$$- [K_{rl}^f] [K_{ll}^f]^{-1} [A_{gl}]^T \{ \ddot{u}_g \} = - [A_{gr}]^T \{ \ddot{u}_g \} \quad (28)$$

Equation (28) can be rearranged as follows:

$$\left([A_{gr}]^T - [K_{rl}^f] [K_{ll}^f]^{-1} [A_{gl}]^T \right) \{ \ddot{u}_g \} = 0 \quad (29)$$

Equation (30) is very important because it defines the volume relationship for an incompressible fluid (i.e., constant volume). This relationship has one row and “g” columns that can be defined in NASTRAN as a multipoint constraint equation. A side effect of the MPC for incompressibility is that all structural and free surface DOF will be coupled, resulting in poor matrix bandwidth and high matrix density for the final Craig-Bampton fluid model and any downstream superelements. This is a computational challenge for both conventional bandwidth-oriented matrix solvers and modern sparse matrix algorithms.

Incompressibility equations are not required when using the “no-slosh” fluid surface option.

2.5. Free Surface Stiffness

If the fluid has a free surface and is in a gravity field, the fluid will have slosh modes caused by “gravity stiffness.” Slosh modes occur in both axial and lateral directions, as illustrated in Figure 2-4. In theory, there exist an infinite number of axial and lateral slosh modes similar to those shown in Figure 2-5. In a finite element model, the number of slosh modes is limited by the finite element mesh. In addition, the accuracy of the calculated slosh modes is controlled by the fluid mesh refinement (see Section 5.1 for additional comments on accuracy).

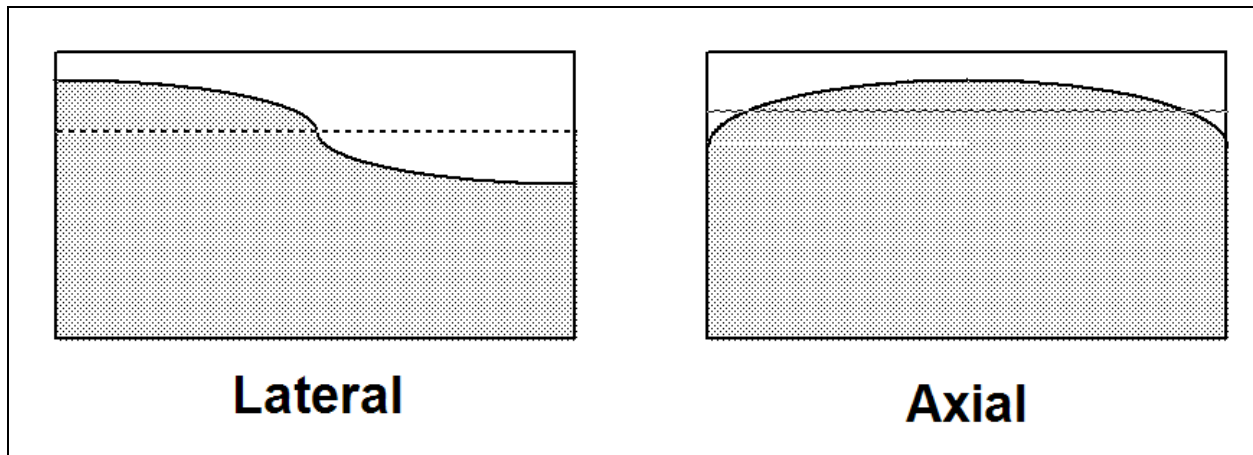

Figure 2-4. Lateral and axial slosh modes occur when the fluid has a free surface and is in a gravity field.

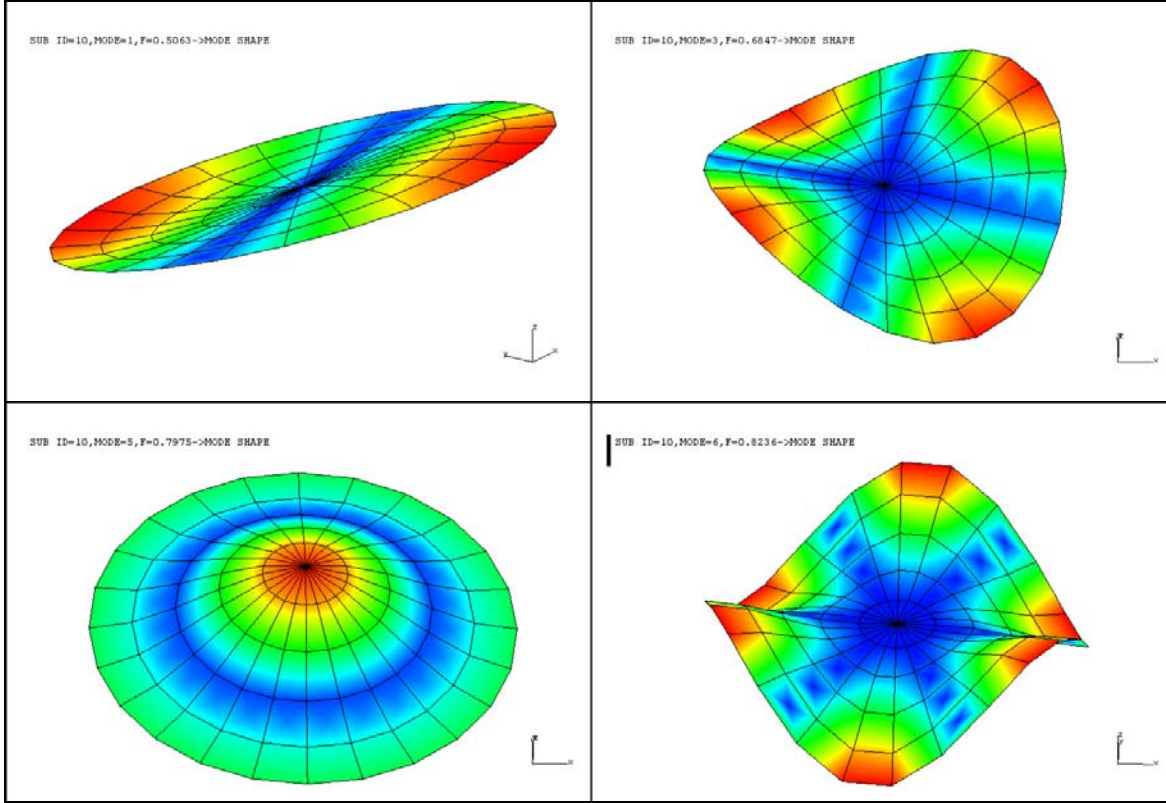

Figure 2-5. Large numbers of axial and lateral slosh modes will exist when the fluid has a free surface.

If the fluid is in a gravity field and is disturbed from its undeformed position, there is a pressure in the fluid caused by displacement relative to the original position:

$$\{p_n\} = \rho g \{u_n\} \tag{30}$$

Both sides of (31) can be pre-multiplied by a special area matrix which includes columns only for the boundary pressure DOF at the free surface:

$$[A_{mn}] \{p_n\} = \rho g [A_{mn}] \{u_n\} \tag{31}$$

Equation (31) can be written in terms of a free surface stiffness matrix:

$$-[A_{mn}] \{p_n\} + [K_{mn}^n] \{u_n\} = 0 \tag{32}$$

where

$$[K_{mn}^n] = \rho g [A_{mn}] \tag{33}$$

A_{nn} is a special area matrix that includes only terms for the free surface. In general, similar terms would appear at all structural wetted surface DOF. However, studies [5] have shown that the gravity stiffness terms are usually several orders of magnitude less than the structural stiffness terms. Therefore, the gravity stiffness terms at the structural wetted surface are neglected. The free surface area matrix is calculated using the same methodology described in Section 2.2 but is limited to columns corresponding to pressure nodes at the free surface.

No free surface stiffness is generated for either the “no-slosh” option or when the fluid is fully enclosed.

2.6. Relative Free Surface

The equations for the free surface stiffness developed in Section 2.5 make the stiffness relative to inertial space. This is correct when the tank is fixed in space, but is not correct when the tank is fixed to a moving body such as a rocket. In this case, the free surface stiffness should be relative to the steady state acceleration which is oriented along the thrust vector. HYDRO offers the option of making the free surface stiffness relative to a grid that can be connected to any DOF on the model. In this case, the fluid free surface stiffness is modified as follows:

$$[K_{NN}^n] = \begin{bmatrix} I_{nn} \\ \Phi_{RB} \end{bmatrix} [K_{nn}^n \quad I_{nn} \quad \Phi_{RB}^T] \quad (34)$$

where

Φ_{RB} - 6 rigid body vectors partitioned to the free surface DOF.

This is the same approach that NASTRAN takes to convert grounded stiffness or flexibility terms for a GENEL element to an element that is ungrounded relative to 6 dependent DOF.

2.7. Fluid Superelement Model

Stiffness and mass matrices are formed for the fluid superelement using the fluid inertance matrix, the area matrix, and the gravity stiffness matrix. The matrices include DOF for structure wetted surface grids and normal displacement DOF at the free surface grids (if any). In addition, the multipoint constraint equation that defines the incompressibility relationship must be applied at the appropriate step in the analysis (more on this later).

If the fluid has a free surface, the normal displacements of the surface can be replaced by generalized coordinates using the Craig-Bampton modal synthesis method [1]. Slosh modes are calculated with the structural wetted surface DOF restrained. There are two significant advantages to using slosh modes (generalized coordinates) to replace the free surface normal displacements. First, the modal frequencies, mode shapes, and modal effective masses are explicitly calculated and provide important information to check the properties and validity of the fluid model. Second, only the generalized coordinates of “significant” slosh modes need to be retained. A slosh mode is considered to be “significant” if it will interact with the structure and/or be excited by the forcing functions. Typically, a significant slosh mode will have large modal effective mass defined as:

$$MEM = MER^2 \quad (35)$$

where

$$MER = \phi^T M \Phi \quad (36)$$

In most cases, only the lower frequency lateral slosh modes will have large effective mass. If the fluid geometry is axisymmetric, the lateral slosh modes will occur in pairs. For an axisymmetric fluid, the first two pairs of lateral slosh modes with large effective mass are typically retained along with the first axial slosh mode⁴, and all other slosh modes are eliminated. This results in a substantial reduction of the hydroelastic model size and prevents unneeded system modes.

If the fluid has a free surface, the MPC set for incompressibility is applied during the Craig-Bampton superelement run. The dependent degree of freedom in the MPC set must be one of the free surface normal displacements. This will cause the maximum number of slosh modes (before eliminating unimportant modes) to be one less than the number of free surface normal degrees of freedom.

If the fluid does not have a free surface (fluid completely enclosed by wetted structure), the MPC set cannot be applied to the fluid model during the Craig-Bampton run. This is because there are no interior hydroelastic DOF that can be made dependent. For an enclosed fluid model, the MPC set must be applied during the processing of the downstream superelement. In this run, one of the structural DOF must be eliminated (made dependent) by the MPC relationship. Note that the

⁴ The 1st axial slosh mode is the first mode that does not come in a pair. It does not have any significant axial effective mass. The axial slosh modes can interact with axial “bulge” hydroelastic modes.

DOF to be eliminated is arbitrary and may be any DOF on the surface with a nonzero area matrix coefficient.

The final results of the hydroelastic finite element model for all cases other than the "fast" option is a set of data blocks that define the fluid model as an NASTRAN superelement. The data blocks created include mass and stiffness matrices and geometry information. Pressure in the fluid is not directly available but could be recovered using the transformation matrices developed to reduce the fluid model. In the case of the "fast" option, the output is a .op2 file with two matrices that can be used to construct the fluid mass. These are input into the structural model using a special-purpose DMAP alter provided with HYDRO.

The superelement representation of the fluid can either be a standard bulk data superelement (defined by SESET cards), DMIG matrices, or any external superelement representation.

2.8. **Coupling the Fluid and Structural Models**

The fluid hydroelastic model is coupled to the structural model using standard superelement methods. NASTRAN automatically fetches the appropriate matrices from the hydroelastic model and adds them to corresponding terms in the structural model. If the fluid model does not have a free surface, the MPC set which imposes incompressibility must be included. If the fluid model has a free surface, insignificant slosh modes can be eliminated by SPC requests. If the fluid model has a relative free surface, the pitch and yaw rotational DOF must be coupled to the structural DOF defining the local acceleration vector.

The specifics of the coupling will depend on which superelement option was chosen. The DMIG option does not use superelements, but requires that the matrices be identified on M2GG and K2GG cards in Case Control. The external superelement⁵ definitions require SEBULK and SECONCT cards in the main bulk data sections along with the EXTBULK cards written to the .pch file when generating the external superelement.

2.9. **Fast Solution Method**

The standard HYDRO methods developed in the previous sections have worked very well for a number of different launch vehicle loads models with relatively coarse FEM meshes. However, for very fine meshes used in stress models, both the computation of the fluid mass matrix and the

⁵ The external superelements are supported in MSC Nastran starting with V2004, and NX Nastran starting with NXN 6.

calculation of the coupled fluid/structure modes can become too computationally expensive. In order to address this concern, a "fast" option for HYDRO was developed, which avoids both the assembly of the mass matrix and the modal solution with the fully coupled mass matrix. It does this by first solving for the structural models without any fluid and then using these modes as a set of basis vectors to reduce the fluid mass matrix to modal coordinates. The equations are then coupled in the modal coordinates and a second eigenvalue solution is executed to calculate the final coupled modes.

The "fast" option has a number of limitations. In its current implementation, it can only be used with a "no-slosh" free surface model (no slosh modes), it cannot be used to recover internal pressures, and it is an approximate method where the accuracy of the approximation is a function of the number of structural modes used in the reduction. However, runs that would take many days to complete or would not be feasible at all can be executed in minutes using this method, and if used with a sufficient number of structural modes it can be very accurate.

Starting with the coupled equations (25) and using the "dry" modes without the fluid mass terms as basis vectors results in the following reduced stiffness and mass matrices:

$$[\Phi_s]^T [K_{gg}^s] [\Phi_s] = [\hat{K}_s], \quad [\Phi_s]^T [M_{gg}^s] [\Phi_s] = [\hat{M}_s] \quad (37)$$

The fluid mass matrix in modal coordinates can then be written as:

$$[\hat{M}_f] = ([\Phi_s]^T [A_{gl}] [K_{ll}^f]^{-1} [A_{gl}]^T [\Phi_s]) \quad (38)$$

Note that the number of columns in $([\Phi_s]^T [A_{gl}]^T [\Phi_s])$ is equal to the number of "dry" modes, which is *much* less than the number of columns in the fluid mass matrix. The mass matrix is only created in modal coordinates, and never in physical coordinates. The coupled modes are calculated in modal coordinates as follows:

$$([\hat{K}_s] - \omega^2 ([\hat{M}_s] + [\hat{M}_f])) \{\phi\} = 0 \quad (39)$$

This method is currently limited to a "no-slosh" fluid surface, and the accuracy is a function of the number of "dry" modes retained in the solution. However, it is much more efficient than the standard HYDRO methods. Because it is currently limited to a "no-slosh" fluid surface, slosh modes are not calculated using this method, and the fluid mass in the plane of the fluid surface does not include the fluid sloshing mass. This accurately represents the coupling of the fluid to

the structure as long as the fluid slosh modes are at a much lower frequency than the structural modes⁶.

⁶ Fluid slosh modes with significant effective mass are typically in the range of 1 Hz, so for most practical problems they are very well separated from the structural modes. Exceptions might be very large fluid storage containers, where the structural modes are also on the order of 1 Hz. It is possible to extend the "fast" formulation to include slosh modes, and this may be implemented in a future version of HYDRO.

3. **OPERATION PROCEDURES**

The HYDRO procedures are implemented as a series of steps shown in Figure 3-1. These steps and all special requirements are described in the following sections.

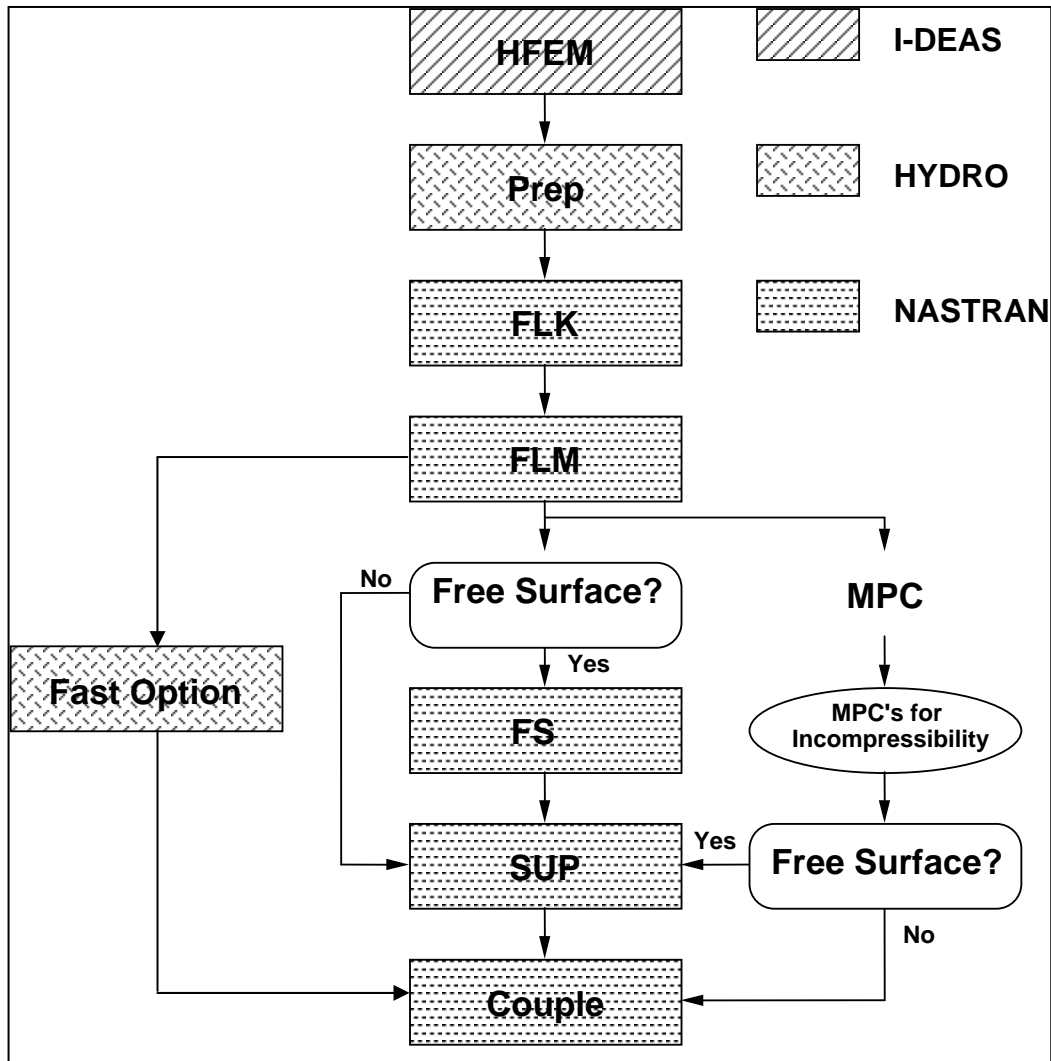

Figure 3-1. The coupled hydroelastic model is formed using NASTRAN and a special Fortran program called HYDRO.

HYDRO reads a NASTRAN input deck, which can be created in any FEM preprocessor such as Femap.

HYDRO offers a number of different options for representing the fluid, depending on whether it has a free surface and how that free surface is represented. The options are:

ENCLOSED	Fluid has no free surface and is in contact with the structure over its entire outer surface.
FIXED	Fluid has a free surface, which is assumed to slosh relative to an inertially fixed gravity vector.
RELATIVE	Fluid has a free surface, which is assumed to slosh relative to a node that moves with the structure.
NO_SLOSH_STD	Fluid has a free surface, but slosh modes are not required. The fluid mass model does not include the sloshing mass on the assumption that the slosh modes are at a much lower frequency than the structural modes.
NO_SLOSH_FAST	Same as the NO_SLOSH_STD option, except that the fluid mass matrix is never assembled in physical coordinates. Instead, the decomposed fluid inertance and area matrices are output to couple the fluid into the structural model using modal coordinates. This is an approximate approach that is many orders of magnitude faster than the standard HYDRO approaches.

The operation of HYDRO varies somewhat depending on the fluid representation chosen. In addition, for all fluid options except for NO_SLOSH_FAST, HYDRO offers a number of choices for the superelement output format. These include:

Standard Bulk Data	Bulk data superelement defined by SESET and CSUPEXT cards
DMIGPCH External	External superelement with matrices written in DMIG format to the PUNCH file
DMIGOP2 External	External superelement with matrices written in DMIG format to an OUTPUT2 file
DMIGDB External	External superelement with matrices written in DMIG format to the database
MATDB External	External superelement with matrices written to the database

MATOP4 External	External superelement with matrices written to an OUTPUT4 file
DMIGPCH Only	Matrices written in DMIG format to the PUNCH file without auxiliary EXTBULK data for external superelement. This option does not require a superelement license to couple the model.

3.1. **Develop Hydroelastic Model**

The first step is to develop the hydroelastic finite element model. The model must include the following items:

- Nodes and solid elements for the fluid
- Nodes and shell elements for the wetted structure
- Nodes and shell elements for the free surface (if any)

The nodes connected by the fluid elements, wetted structure elements, and free surface elements must be independent. This will result in coincident nodes at the fluid/structure and fluid/free surface interfaces as shown in Figure 3-2. Note that at the fluid/structure/free surface “corner” there will be three coincident nodes at each location.

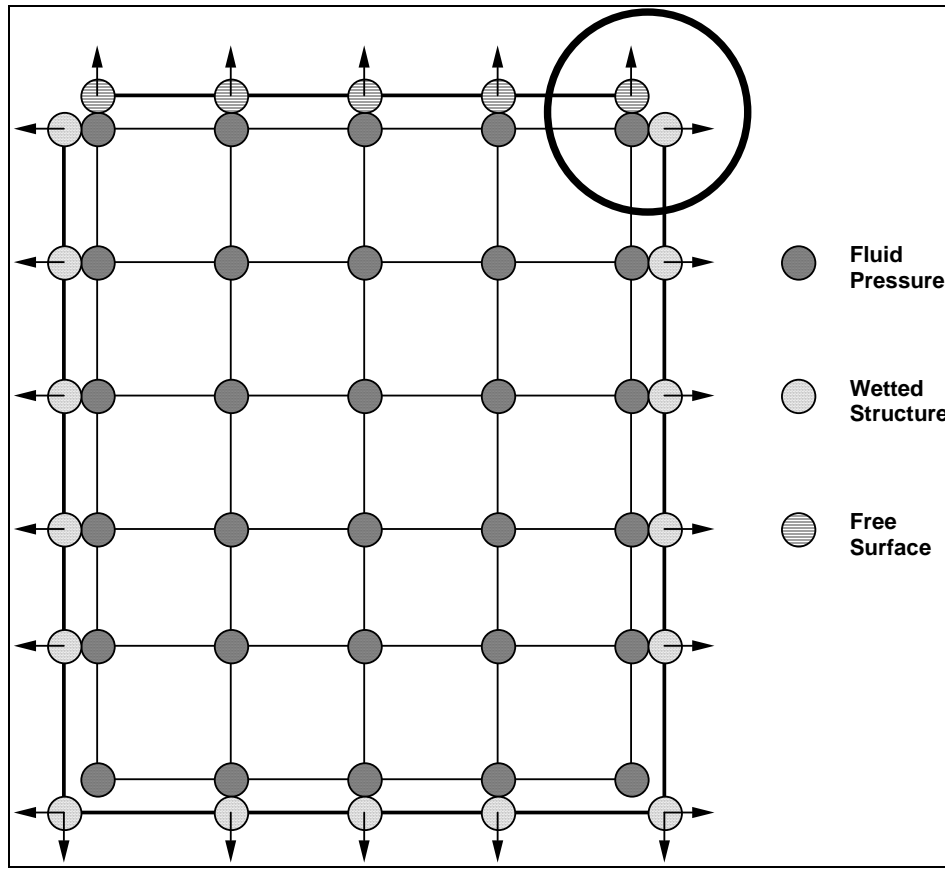

Figure 3-2. There will be three coincident nodes at the intersection of the fluid, wetted-structure and free surface.

The **nodes** must be defined with the following **requirements**:

- The coincident fluid/structure and fluid/free surface nodes must be coincident within a tolerance defined by the user at the time of the HYDRO run. This tolerance should be smaller than the smallest element size in the model. The default is 0.01.
- The ID numbers (labels), locations, and displacement coordinate systems orientation of the wetted structure nodes must be **exactly the same** as the structural model to which the hydroelastic model will be later coupled. The ID numbers for the free surface and fluid nodes are arbitrary.
- The free surface, if present, must be flat and normal to the gravity vector.
- The displacement coordinate system of the free surface nodes must be oriented such that the **displacement Z axis** is parallel to the gravity vector (normal to the free surface) and pointing away from the fluid (up).

The fluid, wetted structure, and free surface **elements** must be defined with the following **requirements**:

- The fluid must be modeled with linear bricks, wedges, or tetrahedrons.
- The wetted structure and free surface must be modeled with linear quadrilateral or triangular shell elements. The shell element type need not be compatible with the

“coated” fluid element type (i.e., a quadrilateral shell can be used to couple to the triangular face of a fluid wedge or tetrahedron). However, there must be a one-to-one correspondence between nodes on the outer surface for the fluid and nodes on the wetted or free surface.

- All shell elements for the free surface must use the same element property ID.
- The orientation (normals) of the wetted structure and free surface shell elements must be defined to be uniformly outward. **Any mixing of shell element normals (some oriented inward while others oriented outward) will produce incorrect results.**
- The property ID numbers for the fluid, wetted structure, and free surface must be unique.
- The fluid model must have no unexpected free edges.
- The properties for the shell and solid elements are arbitrary. They are not used at any time in the HYDRO procedures.

A typical hydroelastic model is shown in Figure 3-3. Note that solid elements are used for the fluid, and shell elements are used for the wetted structure and free surface. In this model, the surface and fluid elements have been moved away from each other to highlight the different elements. In the actual model, these must be coincident.

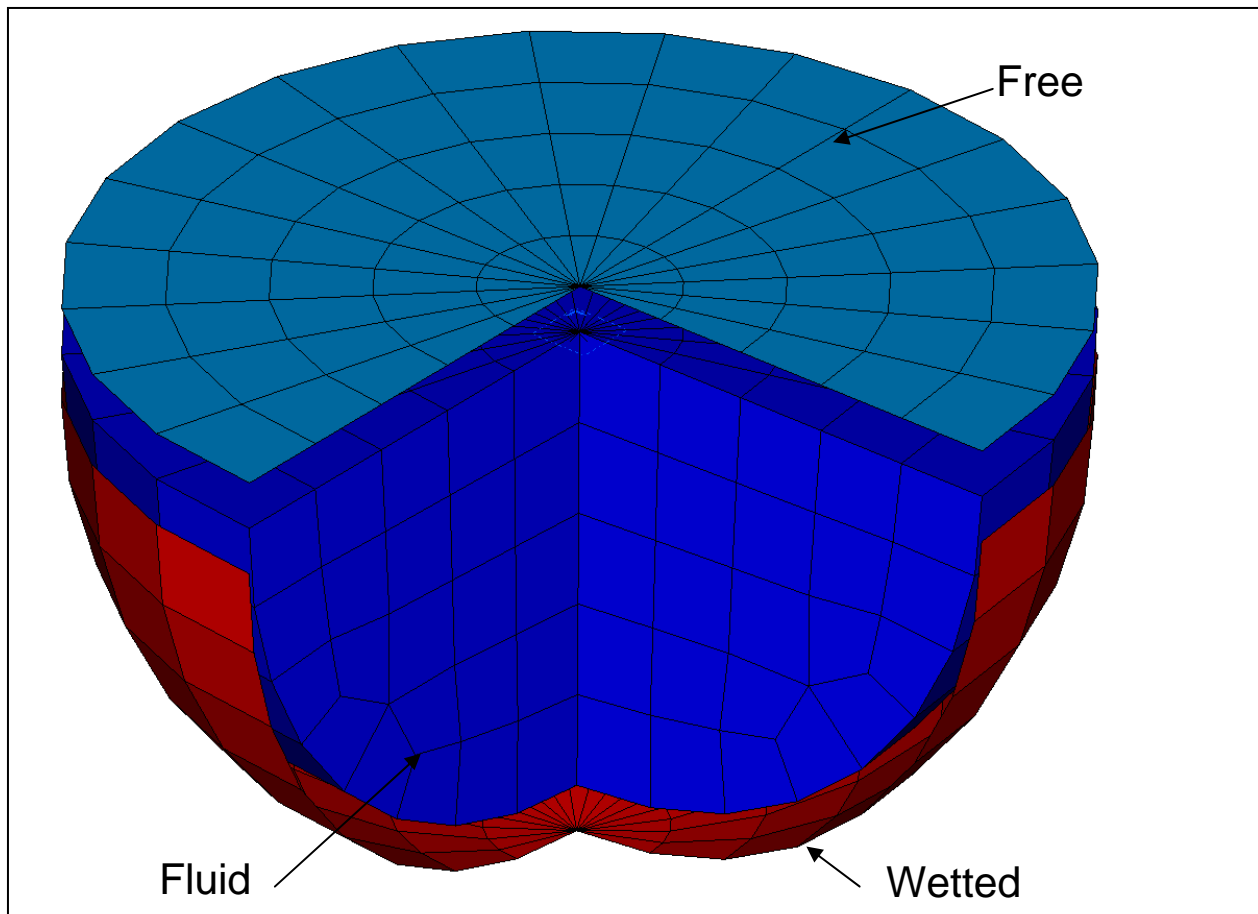

Figure 3-3. The hydroelastic finite element model will include solid elements for the fluid and shell elements for the wetted structure and free surface (exploded view).

Several checks are highly recommended to verify the accuracy of the hydroelastic model. The checks include:

- Fluid mass properties
- Element distortion
- Free edge checks for the fluid, wetted structure, and free surface elements
- Orientation of the shell elements for the wetted structure and free surface

These checks are described in more detail in Chapter 5.

After completing the definition and checking of the hydroelastic model, it is written as a NASTRAN input deck (bulk data). This file is read by the HYDRO program as described in the next section.

3.2. HYDRO “Prep” Run

A program called HYDRO prepares several NASTRAN input decks. The specific decks created depend on the fluid option chosen. HYDRO is run two times for each hydroelastic model when using the ENCLOSED, FIXED, or RELATIVE fluid options. The second run is not required for the NO_SLOSH_STD or NO_SLOSH_FAST options. The first HYDRO run reads the NASTRAN input deck with fluid, wetted surface, and free surface elements and prepares the following series of NASTRAN input decks:

- **FLK** - Generates the fluid inertance (stiffness) matrix and reduces it to the fluid boundary DOF.
- **FLM** - Generates the area matrices, transforms the fluid inertance matrix to an equivalent mass matrix, and calculates the incompressibility relationship.
- **FSK** - Generates the free surface area matrix and the gravity stiffness matrix. This run is only executed for a sloshing surface (FIXED or RELATIVE) option.
- **SUP** - Forms the Craig-Bampton hydroelastic model including slosh modes.

Each deck includes the appropriate nodes and elements (fluid for the FLK run and surface for the FLM, FSK and SUP runs), along with the NASTRAN DMAP required to perform that step. The FSK and SUP runs are not generated for the NO_SLOSH_FAST option.

The second HYDRO run writes the MPC equation for incompressibility. This run is described in Section 3.6.

The HYDRO “prep” run performs the following operations:

- Identifies the fluid nodes (any node connected to a solid element).
- Identifies the fluid boundary nodes (any fluid node coincident with a node connected to either the wetted structure or the free surface shell elements).
- Identifies the wetted structure nodes (any node coincident to a fluid boundary node but not connected to a free surface shell).
- Identifies the free surface nodes (any nodes connected to the free surface shell elements).
- Generates the FLK input deck including grids, elements, properties, and ASET information to calculate the fluid inertance (stiffness) matrix and reduce it to the fluid boundary DOF.
- Generates the FLM input decks including grids, elements, properties, and load information to generate the area matrices.
- For either the FIXED or RELATIVE option, generates the FSK input decks including grids, elements, properties, and load information to generate the free surface stiffness matrix.
- All options other than NO_SLOSH_FAST, generate the SUP input deck including grids and superelement data to define the fluid superelement. The superelement format is fixed at the SUP run, so different superelement output options can be run by modifying this run.

The inputs required for the HYDRO “Prep” depend on the options chosen as summarized in Table 3-1.

Table 3-1. Summary of input for the HYDRO “Prep” run.

	OPTION	ENCLOSE D	FIXED	RELATIVE	NO_SLOSH_ST D	NO_SLOSH_FAS T
1	NASTRAN bulk file to read	required	required	required	required	required
2	free surface (y/n) ?	N	Y	Y	Y	Y
3	Surface option	N/A	fixed	relative	no_slosh_std	no_slosh_fast
4	New free surface reference node	N/A	N/A	required	N/A	N/A
5	Existing free surface node	N/A	N/A	required	N/A	N/A
6	free surface PID	N/A	required	required	required	required
7	coincident node tolerance	optional	optional	optional	optional	optional
8	fluid type or density	required	required	required	required	required
9	gravity magnitude	N/A	required	required	N/A	N/A
10	fluid pressure reference node	required	required	required	N/A	N/A
11	superelement ID	required	required	required	required	N/A
12	pressure recovery nodes	optional	optional	optional	optional	N/A
13	nastran version number	required	required	required	required	required
14	nastran buffer size	optional	optional	optional	optional	optional
15	pressure model database	required	required	required	required	required
16	fluid superelement database	required	required	required	required	N/A
17	fluid stiffness input file (FLK)	required	required	required	required	required
18	fluid area matrix/mass input file (FLM)	required	required	required	required	required
19	Output2 file written by FLM run	N/A	N/A	N/A	N/A	required
20	free surface stiffness input file (FSK)	N/A	required	required	N/A	N/A
21	fluid superelement input file (SUP)	required	required	required	required	N/A
22	Template for coupled system run (CPL)	optional	optional	optional	optional	optional
23	first Q-set node	N/A	required	required	N/A	N/A
24	max frequency for modes	N/A	required	required	N/A	N/A

The inputs are defined as follows:

1. Name of NASTRAN bulk data file with fluid and surface elements (HFEM model).
2. Does the fluid have a free surface?
3. Type of free surface (FIXED, RELATIVE, NO_SLOSH_STD or NO_SLOSH_FAST).
4. SE Format. Either standard bulk data, one of the external superelement options or DMIGPCH only.
5. A number for a node that will be added to the model for the RELATIVE surface option. The stiffness of the free surface will be relative to this node. This node should not exist in the HFEM.

6. Property ID of the PSHELL card defining the free surface elements.
7. Maximum distance for two nodes to be coincident (default is 0.01)
8. User can either select from a menu of predefined fluid densities (in inch units) or enter a value for the fluid mass density.
9. Magnitude of gravity vector on free surface in units of length/time².
10. A node number on the outer surface of the fluid elements. All pressures will be calculated relative to this node. It is usually chosen on the free surface of the fluid, but it must be a fluid node and not a surface node. Only required for the ENCLOSED, FIXED, and RELATIVE options.
11. ID number of the superelement created in SUP run. Not applicable to the NO_SLOSH_FAST option.
12. One or more node numbers on the outer surface of the fluid used for pressure recovery. A recovery matrix will be written in OUTPUT4 format that gives the pressure as a function of the fluid surface accelerations. Not available for the NO_SLOSH options.
13. Version of NASTRAN to be used (V2004, V2005, NX3, NX4, etc.). The available options are controlled by the availability of the corresponding DMAP alters in the executable directory.
14. Increased NASTRAN buffer size if required.
15. Database name for FLK, FLM and FSK runs.
16. Database name for SUP run.
17. Name of the NASTRAN input file for the FLK run.
18. Name of the NASTRAN input file for the FLM run.
19. Name of the OUTPUT2 file from the FLM run for the NO_SLOSH_FAST option. This file cannot have the same name as the _FLM run with an .op2 file type. The default is a .ou2 file type.
20. Name of the NASTRAN input file for the FSK run.
21. Name of the NASTRAN input file for the SUP run.
22. Name of the NASTRAN input template file to couple with the structure.
23. SPOINTs to create DOF for slosh modes using FIXED or RELATIVE options.
24. Number of modes to calculate using the FIXED or RELATIVE options.

The HYDRO program can be run in two modes. The default is the GUI mode, illustrated in Figure 3-4, which is executed by typing *hydro* at a Windows command line prompt, or by double-clicking on the *hydro.exe* icon. HYDRO also works in a command line mode, where the user is prompted for inputs. This mode is executed by entering *hydro -t* at a command line prompt. On the GUI, the processing option (“Prep” or “MPC”), the slosh option, and the

NASTRAN version are all selected from pull-down menus. The form changes to reflect the appropriate inputs for that selection of options. Alternatively, an input file can be prepared and read using *hydro -t <file.inp*. In the command line version, the user is only prompted for those inputs that are relevant to the selected options. Both methods for running HYDRO are covered in Section 4.1.2.

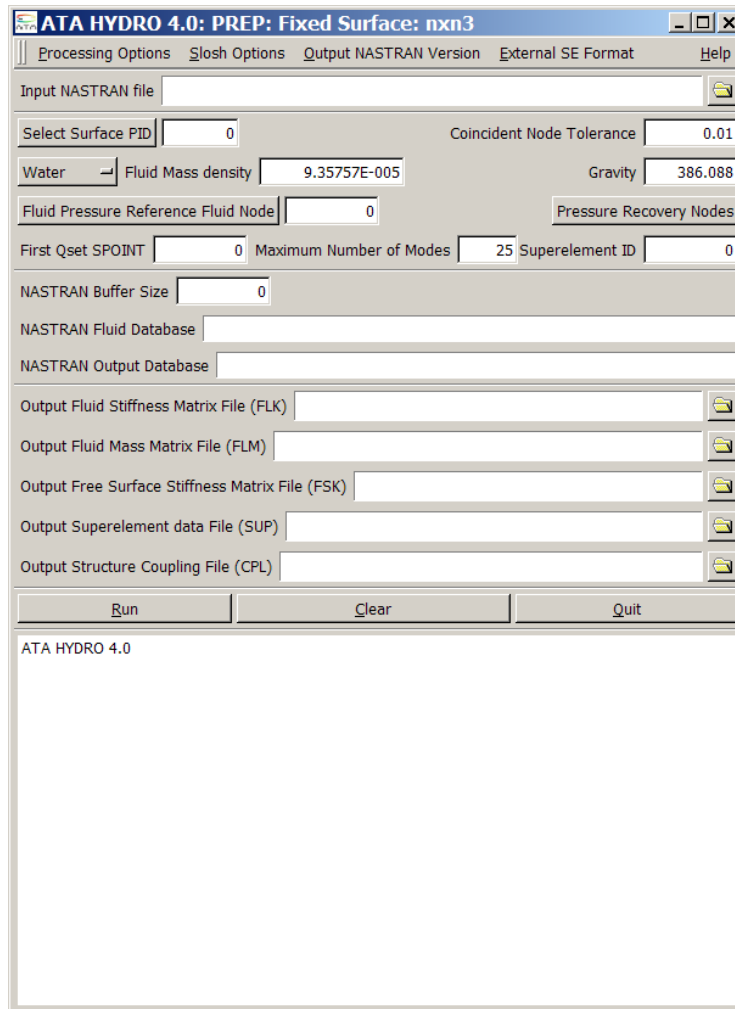

Figure 3-4. HYDRO graphical user interface.

The FLK, FLM, FSK, and SUP runs using the decks prepared by HYDRO are discussed in the following sections.

3.3. **FLK – Generate Fluid Inertance (Stiffness) Matrix**

The FLK run generates the fluid inertance (stiffness) matrix and reduces it to the fluid boundary DOF. The run is a heat transfer analysis and uses the fluid/heat transfer analogy for the element and material properties. A special DMAP sequence performs the required operations.

ASET cards are included to identify the fluid boundary grids. For all options other than the “no-slosh,” a SUPORT card is written to identify the fluid boundary grid that will be used as the reference point for the fluid pressure. See Section 2.3 for more information on the fluid pressure reference point.

The data for the fluid model and inertance (stiffness) matrix is stored in a database. The database dictionary is printed at the completion of the run and at a minimum should contain the PKLL datablock. For all cases other than “no-slosh,” it should also contain the PVALR and PKLR datablocks.

3.4. **FLM – Generate Fluid Mass Matrix**

A NASTRAN run is performed to generate the area matrix and the fluid mass matrix. The run generates load vectors to form the area matrix. After completing all columns of the area matrix, the fluid inertance (stiffness) matrix generated by the FLK run is either converted to an equivalent mass matrix at the wetted structure and free surface DOF, or in the case of the NO_SLOSH_FAST option decomposed and written in OUTPUT2 format for coupling with the structure. The FLM run is performed as a restart run using the database created in the FLK run.

The Bulk Data deck includes grids and shell elements for the wetted structure. PLOAD4 cards are included to define the unit fluid pressures. The load generation capability in NASTRAN is used to convert the fluid pressures to equivalent structural forces. These terms make up the area matrix.

For all cases other than the NO_SLOSH_FAST option, the fluid inertance (stiffness) matrix is converted to an equivalent mass matrix at the wetted structure and free surface DOF, and the NASTRAN Grid Point Weight Generator output is printed⁷. The user should check this output carefully to make sure that the fluid mass is correct. For the ENCLOSED, FIXED, and RELATIVE options, the fluid mass should be the same in all three directions and should be equal to the fluid volume times its density. Any deviation from these results indicates an error in the model. For the NO_SLOSH options, the slosh modes are not calculated, but the sloshing mass is removed in the lateral direction. This means that only the mass component normal to the free surface will equal the fluid volume times its density. In the other two directions, the mass

⁷ When using the NO_SLOSH_FAST option, the mass properties are not output in NASTRAN Grid Point Weight Generator format. Instead, the mass matrix about the origin is output in MATPRN format as matrix MRIG. The (1,1), (2,2) and (3,3) elements of this matrix are then written as “messages.”

will be less. For typical models, the lateral mass components are anywhere from 10% to 80% less than the total mass.

For all options other than NO_SLOSH_FAST, the area matrix and fluid mass matrix are stored in the database. After the final FLM run, the database dictionary is printed at the completion of the run and should contain the following additional data blocks:

AGP	Area matrix (structure g-set to pressure model)
FMOO	Fluid mass matrix – o-set partition (FIXED/RELATIVE options only)
FMAO	Fluid mass matrix – o-to-a coupling partition (FIXED/RELATIVE options only)
FMAA1	Fluid mass matrix – a-set partition

For the ENCLOSED, FIXED, and RELATIVE options, the MPC coefficients are written in DMIG format to the .pch file for processing by the HYDRO “MPC” run. These are not required or output for either of the NO_SLOSH options.

When using the NO_SLOSH_FAST option, the area matrix (AGP) and the decomposed fluid inertance matrix (LDLL) are written to an OUTPUT2 file for coupling with the structure. In this case, the fluid database is not used and no superelements are created.

3.5. **FSK – Generate Free Surface Stiffness Matrix**

The FSK run is needed only if the fluid has a free surface. The FSK run is not needed and is not generated by the HYDRO program when using the ENCLOSED option.

The FSK run is similar to the FLM run. The FSK run generates the free surface area matrix and the gravity stiffness matrix. It also generates load vectors to form the free surface area matrix. After completing all columns of the area matrix, the gravity stiffness matrix is calculated by multiplying the free surface area matrix by gravity and fluid density, as described previously in Section 2.5. The FSK run is performed as a restart run using the database accessed by the FLK and FLM runs.

The Bulk Data deck includes grids and shell elements for the free surface. PLOAD4 cards are included to define the unit fluid pressures. The load generation capability in NASTRAN is used to convert the fluid pressures to equivalent structural forces needed for the area matrices.

In the final FSK run, the free surface stiffness matrix is formed by multiplying the free surface area matrix by gravity and fluid density. No special checks are performed for the accuracy of the

free surface stiffness matrix since any errors in the free surface definition would have been detected during the FLM runs.

The free surface area matrix and stiffness matrix are stored in the database. After the final FLK run, the database dictionary is printed at the completion of the run and should contain the following data blocks:

FSK1	Area matrix (free surface nodes to pressure model)
FKGGDMIG	Free surface stiffness matrix (MTRXIN DMIG format)

3.6. **HYDRO “MPC” Run**

A second run of the HYDRO program is required after completing the FLM sequence of runs only when using the ENCLOSED, FIXED, or RELATIVE options⁸. The second HYDRO run reads the NASTRAN punch file (.pch) from the FLM run and writes MPC statements that define the incompressibility relationship. The following information is entered interactively for the second HYDRO run:

- HYDRO operating mode (MPC)
- Name of the final FLM .F06 file
- MPC set number
- Dependent DOF

For a fluid model with a free surface, the dependent DOF must be one of the free surface normal displacements and should be in the Z direction (normal to the surface). For a fluid model without a free surface, the dependent DOF must be a wetted structure DOF with a non-zero MPC coefficient.

3.7. **SUP – Generate Hydroelastic Model Superelement**

The SUP run combines the results from the previous runs to form the hydroelastic model superelement. The run generates the geometry data blocks required for a superelement and formats the fluid matrix into final form. For the FIXED or RELATIVE options, slosh modes are calculated and used to form the component mode generalized mass and stiffness matrices. If slosh modes are calculated, the fractional modal effective mass results are also written to the .f06 in order to facilitate the selection of important slosh modes. After completing the SUP run, the hydroelastic model is defined as either a standard NASTRAN superelement, as DMIG cards, or as an external superelement. All output options for an external superelement are supported.

⁸ The MPC run is not required for either of the NO_SLOSH options.

These include MATDB, DMIGDB, DMIGOP2, DMIGPCH, and MATOP4. The SUP run is not executed for the NO_SLOSH_FAST option.

The data blocks to define the fluid superelement are either stored in the database or on an external file, depending on the superelement option chosen. The database dictionary is printed at the completion of the SUP run and should contain standard data blocks to define a NASTRAN superelement. If any of the external superelement options other than DMIGDB or MATDB are chosen, the matrices are written to an external file. In the case of the external superelement options, an .asm file is written by HYDRO to be included in the main bulk data section of the coupling run and a .pch file is written by the SUP run to define the PART superelement.

3.8. **Coupling of Fluid Superelement to Structural Models**

For all cases other than the NO_SLOSH_FAST option, the fluid superelement is coupled to the structural model using standard methods. At this point in the HYDRO procedure, the fluid superelement is recognized as a bulk data or external NASTRAN superelement. The assembly of the fluid into the model depends on the type of superelement but does not require any special DMAP or other processing.

A template for this coupling run is provided by HYDRO. The template includes everything except for the structural model, which must be added. The form of the coupling run depends on the output format. For a standard bulk data superelement, it includes the free surface grids (if any), the CSUPEXT statements defining the exterior wetted surface grids, and the grids and SEQSET statements for the generalized coordinates of the slosh modes (if any). SPC statements can be defined to restrain (eliminate) unimportant slosh modes. If the fluid superelement is completely enclosed (no free surface), the MPC data for incompressibility must be included and processed in the downstream superelement.

For external superelements, two files need to be included for each fluid superelement. The first is the .asm file created by HYDRO. This file includes the SEBULK card required to define the external superelement format, the SECONCT card to connect it to the corresponding GRIDs in the structure, and the SPOINT cards to define the slosh modes. The second is the .pch file from the SUP run. This file includes the BEGIN SUPER card for the superelement, as well as all other required input to define the external superelement. The coupling run includes both of these, and assignments to the external superelement matrix files.

For external superelements, a DMAP alter that allows the scaling of the matrices to represent different fluid weights and steady state accelerations is also included. The concept is that a fluid superelement will be developed for a particular tank fill level in a 1G acceleration field. This fluid model will then be scaled to match a specific fluid weight and acceleration for a particular point in the flight trajectory. The user simply enters the desired fluid mass and the acceleration (in Gs), and the DMAP alter does the scaling of the fluid matrices. The mass matrix is scaled by the ratio of desired to modeled mass, and the stiffness matrix is scaled by the product of that factor multiplied by the acceleration. This facilitates the use of a single fluid model to represent slightly different fluid weights. A different fluid model should still be used if the fill level changes significantly.

If the fluid superelement has a free surface, the model will contain a large number of slosh modes. Most of the slosh modes are not important because they have very small effective mass and will not contribute to overall responses. The critical modes to keep are the lateral slosh modes. If the fluid model is symmetric, the lateral slosh modes will occur in pairs. Typically, only the first three or four lateral slosh mode pairs are important and should be retained. If desired, the axial slosh modes can also be retained, although these modes have very low effective mass and are unlikely to contribute to axial responses. The unimportant modes are eliminated by placing the appropriate degrees of freedom of the generalized coordinates on SPC or SPC1 cards. For a Craig-Bampton model, restraining a generalized coordinate eliminates that mode but does not impose any grounding on the structure.

The coupled hydroelastic modes are calculated using a standard eigensolver (Lanczos method recommended for most problems). The mode shapes can be displayed using any NASTRAN postprocessor. If the slosh modes are important, a special “display” model can be created that includes both the structural model and “display” shell elements for the free surface. This allows the display of the vertical motion of the free surface as well as the motion of the structure. Note that the lateral motion of the free surface will be zero since the lateral degrees of freedom are not defined by the free surface area matrix (see Section 2.5). Therefore, some engineering judgment is required to interpret the mode shapes of the “display” model including the free surface.

3.9. **Coupling of Fluid to Structural Models Using FAST Option**

When using the NO_SLOSH_FAST option, the fluid is coupled to the structural model using a special process that requires an additional DMAP Alter. HYDRO creates a template for this run that contains everything except for the structural model. The coupled solution is based on a two-step modal approach, where the first set of modes is calculated without the fluid and then used as

a basis to reduce the fluid mass matrix before calculating the second set of modes. The coupled solution run is identical to a standard modal analysis run with the following changes:

1. An INPUTT2 file assignment is required to locate the OUTPUT2 file from the FLM run. This should be assigned to UNIT 11.
2. The *hydro_couple.xxx* alter must be included immediately before the CEND card.
3. SPOINTs must be defined as DOF to store the first set of modes.
4. The SPOINT DOF must be placed in the Q-set using QSET or QSET1 cards.
5. Optionally, physical DOF can also be added to the basis vectors using BSET or BSET1 cards.
6. A PARAM,METHCMRS and a corresponding EIGRL card must be included to define the modal parameters for the first set of modes.

A typical section of the bulk data deck is listed in Figure 3-5. In this case, 250 modes are calculated in the first pass, and the six DOF on node 31501 are added to the BSET.

PARAM	METHCMRS	1000		
EIGRL	1000			250
SPOINT	99000	THRU	99250	
QSET1	0	99000	THRU	99250
BSET1	123456	31501		

Figure 3-5. Bulk data added to standard modes run to perform "fast" coupled fluid solution.

The fluid mass properties and both sets of modes (without and with fluid) are written to the .f06 file. The user should check that these mass properties are correct and that the modal frequencies with the fluid are different than the modal frequencies without the fluid.

4. EXAMPLE PROBLEMS

Two example problems are presented in this chapter to illustrate the HYDRO procedures. The first example problem is a hemisphere of water in the bottom of an axisymmetric thin-walled tank. This example provides a good illustration of the input and output for a typical hydroelastic model. The second example problem is more advanced and illustrates defining a “relative” free surface and an annular fluid volume.

4.1. Fluid Hemisphere and Cylindrical Tank

The first example problem is a hemisphere of water in the bottom of an axisymmetric thin-walled tank, as shown in Figure 4-1. This model includes many important features including special definition and displacement coordinate systems. In addition, an exact solution is available for a fluid hemisphere to verify the accuracy of the solution.

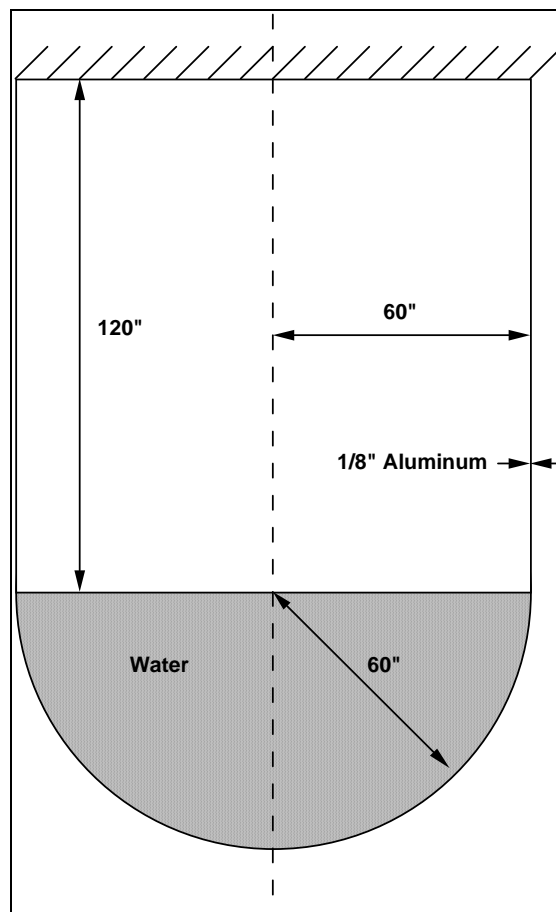

Figure 4-1. The example problem includes a hemisphere of water in a thin-walled tank.

The example problem is presented in the following steps:

- Creating the hydroelastic finite element model in I-deas
- Running the HYDRO program to develop the NASTRAN input decks
- Performing the FLK run
- Performing the FLM run
- Performing the FSK run
- Running the HYDRO program to write the MPC for incompressibility
- Performing the SUP run
- Coupling the fluid superelement to the structure

4.1.1. I-deas Hydroelastic Finite Element Model

The hydroelastic finite element model was created by revolving a cross section to create the complete model. To start the cross section mesh, a mesh area was created for the fluid illustrated in Figure 4-1. Shell elements for the fluid cross section were created using the automatic mesh generator, as shown in Figure 4-2. Nodes at the fluid/wetted structure interface were copied from the fluid nodes. These new wetted structure nodes had the same ID numbers and displacement coordinate systems as the structural model described in Section 4.8.

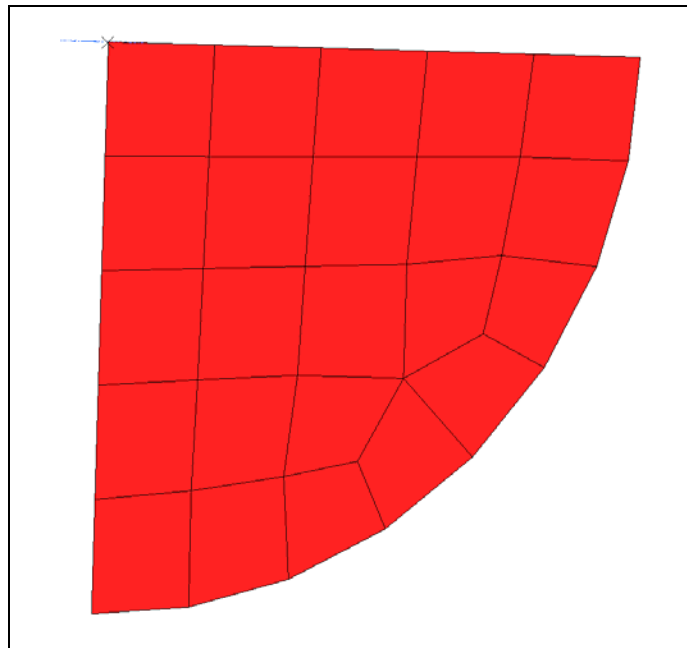

Figure 4-2. A cross section of the fluid was meshed.

The completed cross section was “revolved” to create the hydroelastic finite element model shown in Figure 4-3. The shell elements in the cross section generated solid brick and wedge elements for the fluid. The original cross section surface was then deleted and the outer surface

was coated with both the wetted surface elements and the free surface elements. The coating was performed in two steps so that the wetted surface elements and free surface elements would not share nodes. In both cases, the master (fluid) nodes were not used for the surfaces so that additional coincident nodes were created.

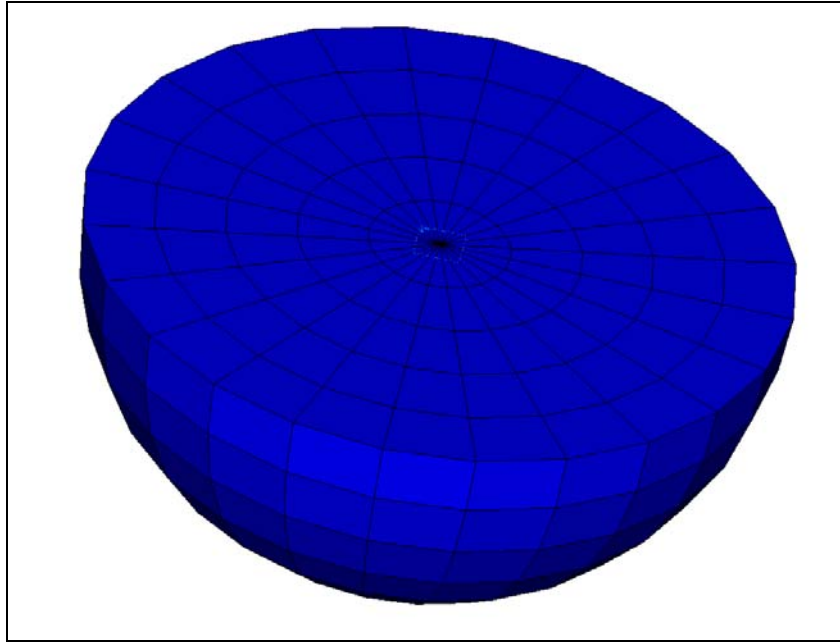

Figure 4-3. The fluid model cross section was revolved to create the hydroelastic finite element model.

The shell element orientation was checked using the element triad display to verify that all shell element normals all pointed outward. As shown in Figure 4-4, all elements were correctly oriented. Free edge checks for the wetted structure and free surface shell elements verified correct definition.

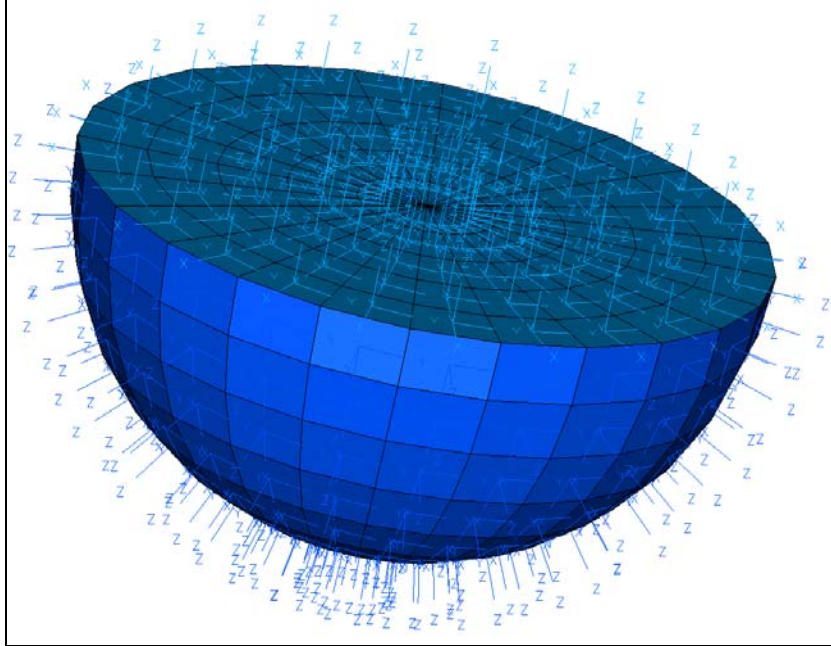

Figure 4-4. The orientation of the wetted structure and free surface shells were checked to verify that their orientation was uniformly outward.

The final hydroelastic finite element model, including the fluid elements, the wetted surface elements, and the free surface elements, was written to a NASTRAN input deck⁹. The NASTRAN input deck is read by the HYDRO program to create the NASTRAN input decks required to represent the fluid.

This model can be used for all options except for the option with no free surface (ENCLOSED). In this case, the structure must cover the top surface of the fluid so that it is fully enclosed. To do this, the structural nodes around the circumference of the flat surface are merged with the wetted surface nodes¹⁰.

4.1.2. HYDRO “Prep” Run

The HYDRO program was run to prepare the NASTRAN input decks, for all five options. The inputs depend on the option chosen, and HYDRO can be run in either command line mode or using the graphical user interface. The inputs are summarized in Table 4-1.

⁹ This file is called hydroex.hfem and is delivered with HYDRO.

¹⁰ This file is called enclosed.hfem and is delivered with HYDRO.

Table 4-1. Inputs to HYDRO run for hemisphere example.

	OPTION	ENCLOSED	FIXED	RELATIVE	NO_SLOSH_STD	NO_SLOSH_FAST
1	NASTRAN bulk file	enclosed.hfem	hydroex.hfem	hydroex.hfem	hydroex.hfem	hydroex.hfem
2	free surface?	N	Y	Y	Y	Y
3	Surface option	N/A	fixed	relative	no_slosh_std	no_slosh_fast
4	Free surface reference node	N/A	N/A	40000	N/A	N/A
5	Existing free surface node	N/A	N/A	30000	N/A	N/A
6	free surface PID	N/A	5	5	5	5
7	coincident node tolerance	.01	.01	.01	.01	.01
8	fluid type or density	water	water	water	water	water
9	gravity magnitude	N/A	386.1	386.1	N/A	N/A
10	fluid pressure reference node	10000	10000	10000	N/A	N/A
11	superelement ID	10	10	10	10	N/A
12	pressure recovery nodes	10002	10002	10002	10002	N/A
13	nastran version number	V2001	V2001	V2001	V2001	V2001
14	nastran buffer size	default	default	default	default	default
15	pressure model database	enclosed_P	fixed_P	relative_P	noslosh_P	fast_P
16	fluid superelement database	enclosed	fixed	relative	noslosh	N/A
17	fluid stiffness input file (FLK)	enclosed_flk.dat	fixed_flk.dat	relative_flk.dat	noslosh_flk.dat	fast_flk.dat
18	fluid mass input file (FLM)	enclosed_flm.dat	fixed_flm.dat	relative_flm.dat	noslosh_flm.dat	fast_flm.dat
19	Output2 file written by FLM run	N/A	N/A	N/A	N/A	fast_flm.ou2
20	free surface stiffness input file (FSK)	N/A	fixed_fsk.dat	relative_fsk.dat	N/A	N/A
21	superelement input file (SUP)	enclosed_sup.dat	fixed_sup.dat	relative_sup.dat	noslosh_sup.dat	N/A
22	Template for coupled system run (CPL)	enclosed_cpl.dat	fixed_cpl.dat	relative_cpl.dat	noslosh_cpl.dat	fast_cpl.dat
23	first Q-set node	N/A	99001	99001	N/A	N/A

	OPTION	ENCLOSED	FIXED	RELATIVE	NO_SLOSH_ST D	NO_SLOSH_FAS T
24	max frequency for modes	N/A	2.5	2.5	N/A	N/A

The input decks for the command line version of HYDRO for the various options are presented in Figure 4-5 through Figure 4-9. Note that only prompts for those inputs that are relevant to the selected option are provided.

```

PREP
enclosed.hfem
N
0.01
water
10000
10
10002

v2001

enclosed_P
enclosed
enclosed_flk.dat
enclosed_flm.dat
enclosed_sup.dat
enclosed_cpl.dat

```

Figure 4-5. HYDRO input for fluid hemisphere example with ENCLOSED option.

```

PREP
hydroex.hfem
Y
NO_SLOSH_FAST
5
0.1
water
v2001

fast_P
fast
fast_flk.dat
fast_flm.dat
fast_flm.ou2
fast_cpl.dat

```

Figure 4-6. HYDRO input for fluid hemisphere example with NO_SLOSH_FAST option.

```
PREP
hydroex.hfem
Y
FIXED
5
0.1
water
386.1
10000
10
10002

v2001

fixed_P
fixed
fixed_flk.dat
fixed_flm.dat
fixed_fsk.dat
fixed_sup.dat
fixed_cpl.dat
99001
2.5
```

Figure 4-7. HYDRO input for fluid hemisphere example with FIXED option.

```
PREP
hydroex.hfem
Y
NO_SLOSH_STD
5
0.1
water
10
10002

v2001

noslosh_P
noslosh
noslosh_flk.dat
noslosh_flm.dat
noslosh_sup.dat
noslosh_cpl.dat
```

Figure 4-8. HYDRO input for fluid hemisphere example with NO_SLOSH_STD option.

```
PREP
hydroex.hfem
Y
RELATIVE
40000
30000
5
0.1
water
386.1
10000
10
10002

v2001

relative_P
relative
relative_flk.dat
relative_flm.dat
relative_fsk.dat
relative_sup.dat
relative_cpl.dat
99001
2.5
```

Figure 4-9. HYDRO input for fluid hemisphere example with RELATIVE option.

The GUI inputs for the various options are illustrated in Figure 4-10 through Figure 4-14.

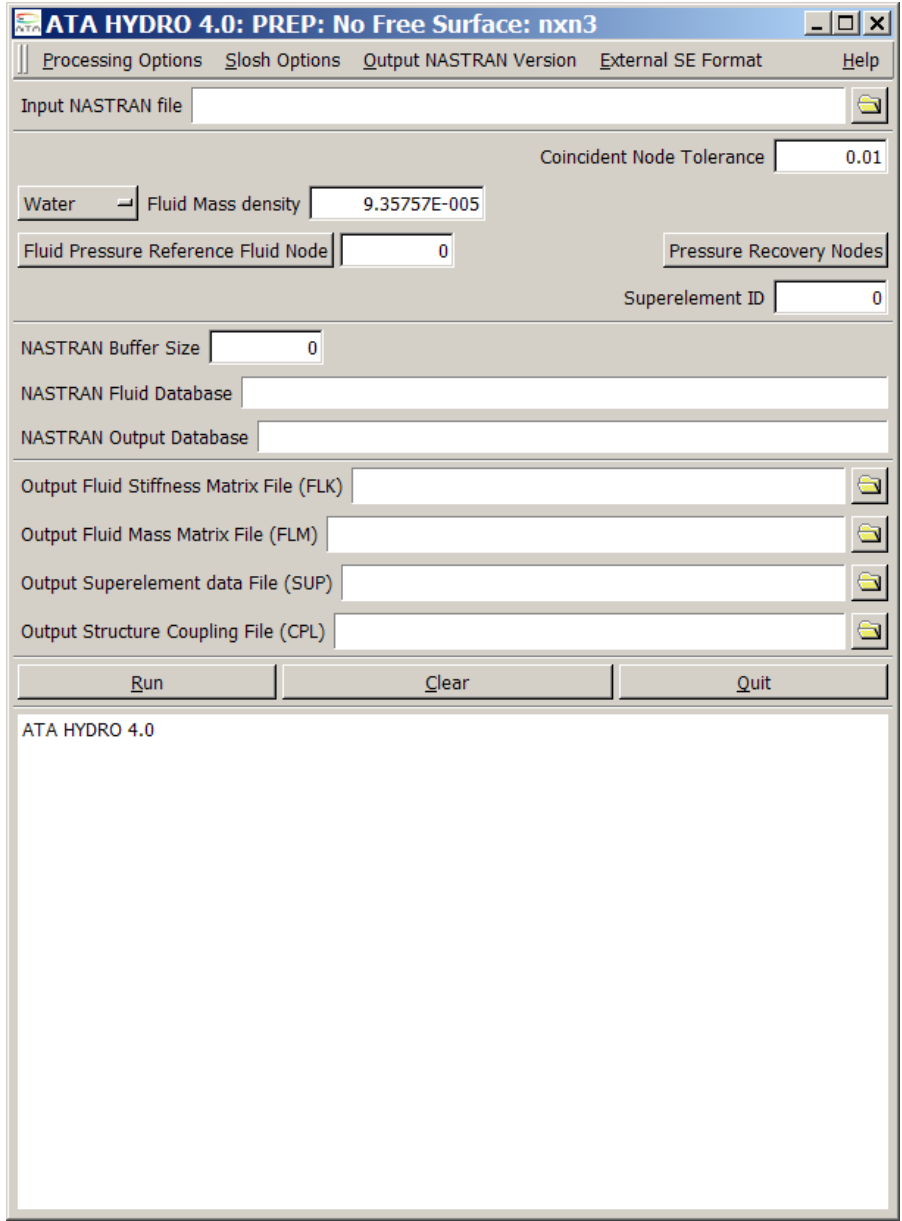

Figure 4-10. HYDRO GUI input for fluid hemisphere example with ENCLOSED option.

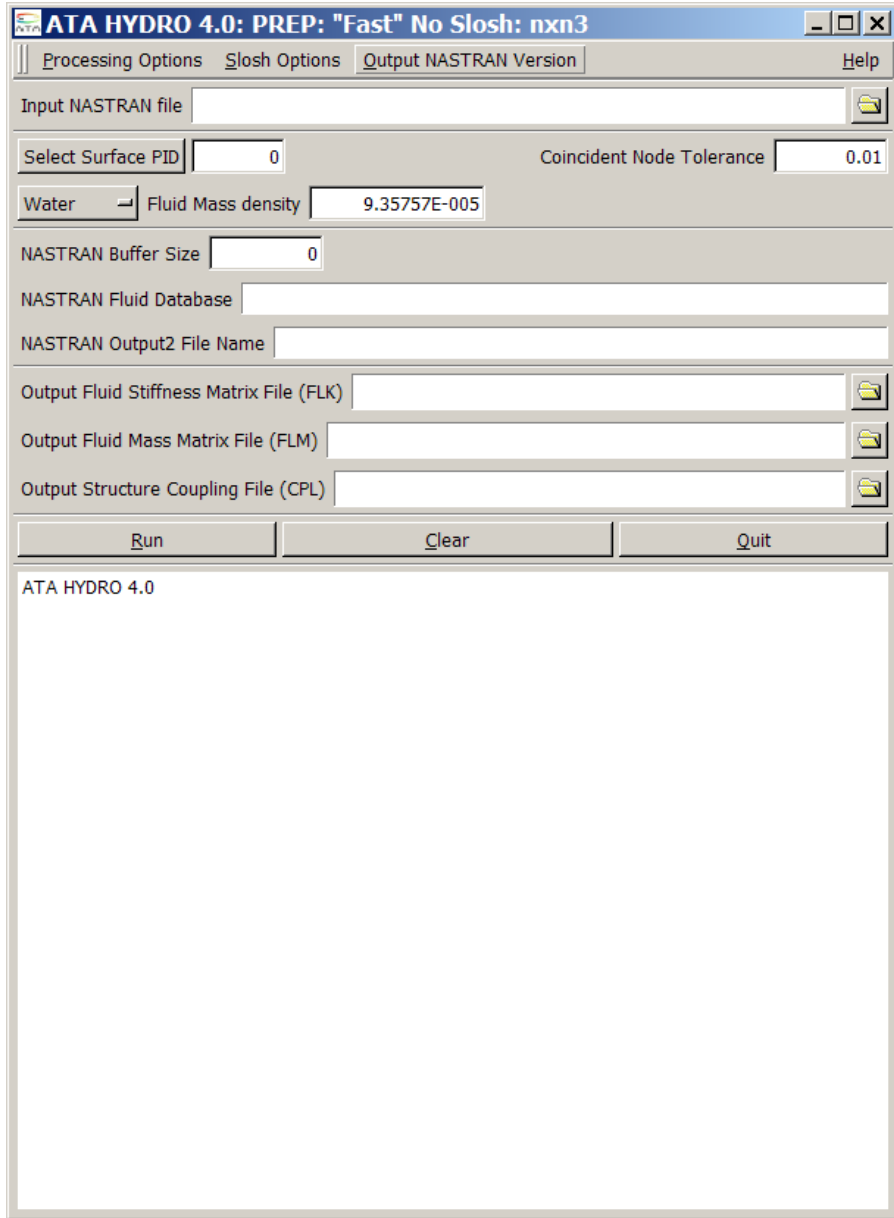

Figure 4-11. HYDRO GUI input for fluid hemisphere example with NO_SLOSH_FAST option.

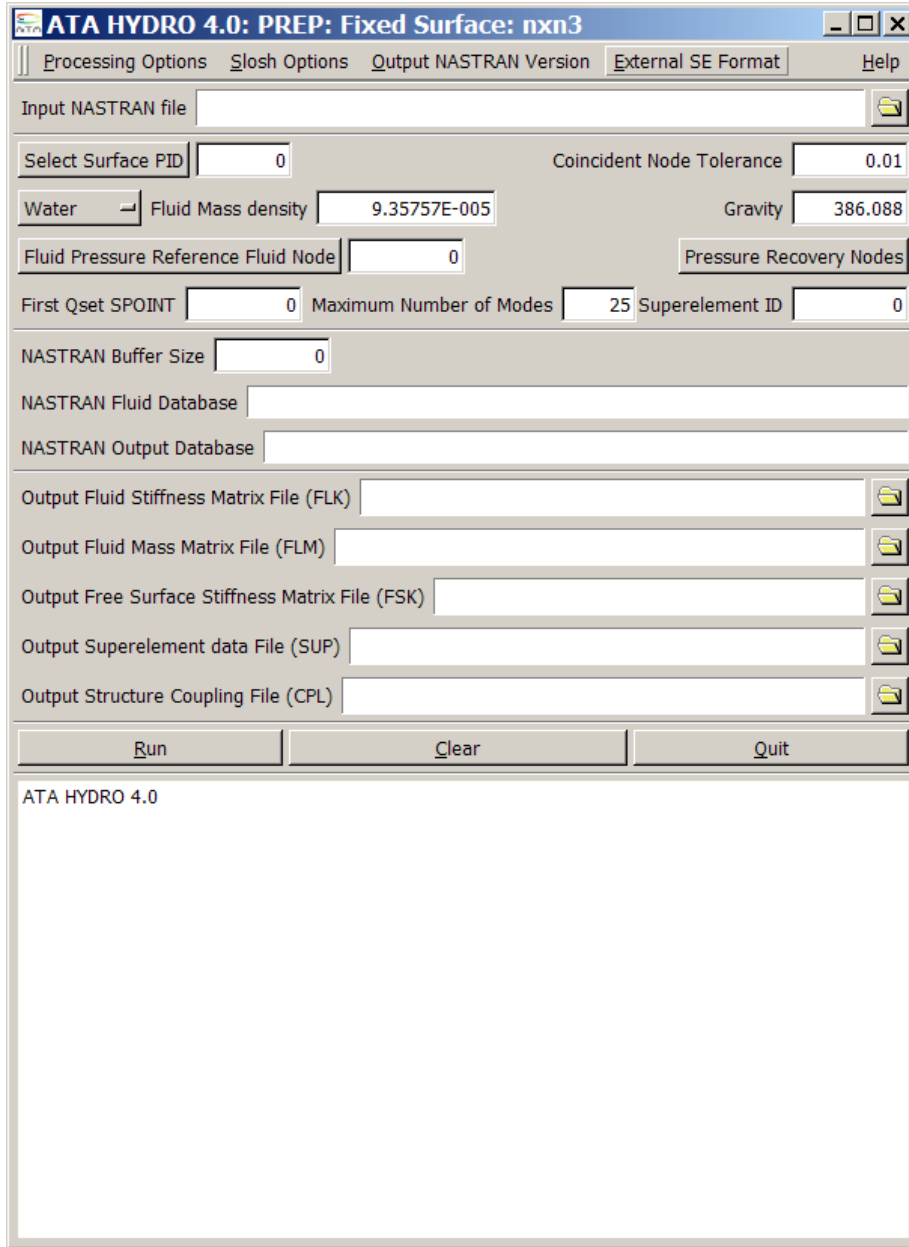

Figure 4-12. HYDRO GUI input for fluid hemisphere example with FIXED option.

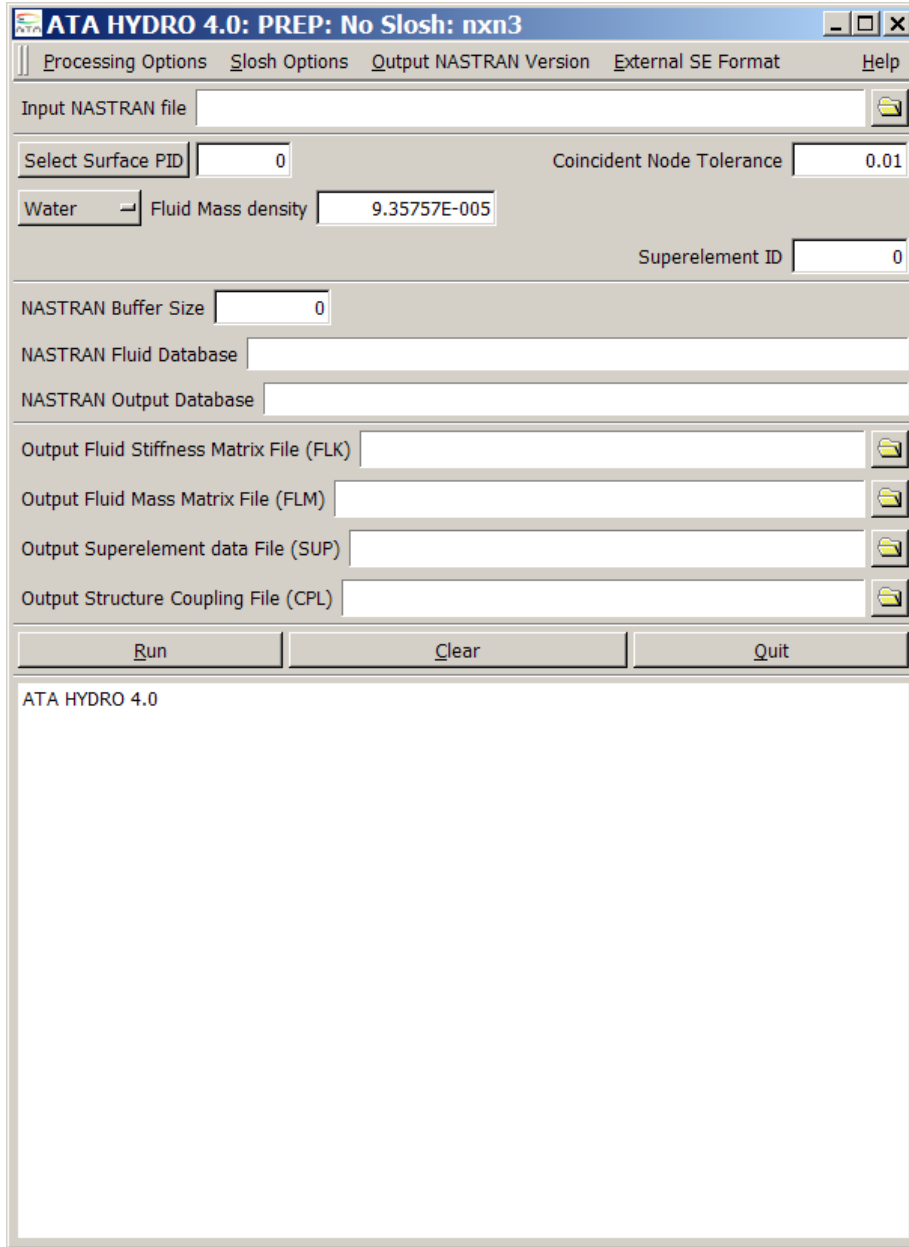

Figure 4-13. HYDRO GUI input for fluid hemisphere example with NO_SLOSH_STD option.

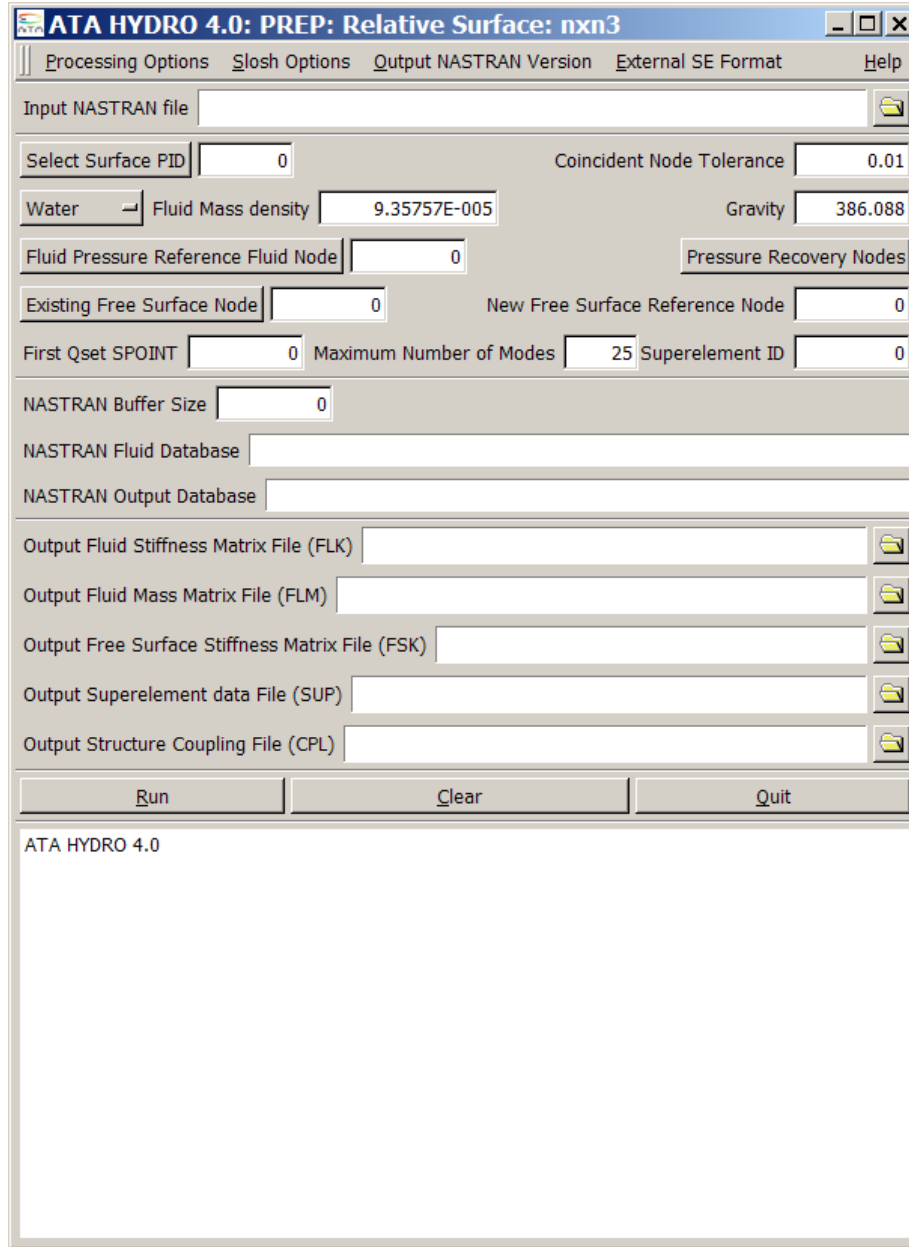

Figure 4-14. HYDRO GUI input for fluid hemisphere example with RELATIVE option.

The HYDRO run generates anywhere from three to five NASTRAN input files:

- *_FLK.DAT - fluid stiffness matrix run (always generated)
- *_FLM.DAT - fluid mass matrix run (always generated)
- *_FSK.DAT - free surface stiffness matrix run (FIXED and RELATIVE options only)
- *_SUP.DAT - fluid superelement run (all but NO_SLOSH_FAST option)
- *_CPL.DAT - template to couple structure to fluid (always generated)

4.1.3. FLK - Fluid Stiffness (Inertance) Matrix

The FLK run generates the fluid inertance (stiffness) matrix associated with the fluid pressure model. This run does not require any editing before executing. The .f06 file should be checked for FATAL errors. For the ENCLOSED, FIXED, and RELATIVE options, the bottom part of the .f06 file will be similar to that illustrated in Figure 4-15. When using the NO_SLOSH_STD or NO_SLOSH_FAST options, the PKRL and PVALR datablocks are not created, and the output is illustrated in Figure 4-16.

```

KEY NUMBER = 687      QUALIFIER NAME AND VALUE
                     ZNAME =PKLL
                     ZUZR1 =          0
                     ZUZR2 =          0
                     ZUZR3 =          0

KEY NUMBER = 688      QUALIFIER NAME AND VALUE
                     ZNAME =PKRL
                     ZUZR1 =          0
                     ZUZR2 =          0
                     ZUZR3 =          0

KEY NUMBER = 689      QUALIFIER NAME AND VALUE
                     ZNAME =PVALR
                     ZUZR1 =          0
                     ZUZR2 =          0
                     ZUZR3 =          0

KEY NUMBER = 690      QUALIFIER NAME AND VALUE
                     ZNAME =PREC
                     ZUZR1 =          0
                     ZUZR2 =          0
                     ZUZR3 =          0

END OF DIRECTORY PRINT
1
* * * END OF JOB * * *
```

Figure 4-15. NASTRAN .f06 file output for FLK run with ENCLOSED, FIXED, or RELATIVE options.

```

KEY NUMBER = 687      QUALIFIER NAME AND VALUE
                     ZNAME =PKLL
                     ZUZR1 =          0
                     ZUZR2 =          0
                     ZUZR3 =          0

KEY NUMBER = 688      QUALIFIER NAME AND VALUE
                     ZNAME =PREC
                     ZUZR1 =          0
                     ZUZR2 =          0
                     ZUZR3 =          0

END OF DIRECTORY PRINT
1                      * * * END OF JOB * * *

```

Figure 4-16. NASTRAN .f06 file output for FLK run with NO_SLOSH_STD or NO_SLOSH_FAST options.

4.1.4. FLM - Fluid Mass Matrix Run

The FLM run generates the area matrix relating the boundary pressure grids to the wetted structure and free surface grids. The area matrix is used to convert the fluid stiffness (inertance) matrix of the pressure model to an equivalent mass matrix at the wetted structure and free surface DOF. The FLM run also calculates the constraint equation coefficients to define a constant volume (incompressible fluid)¹¹.

A critical item printed in the .f06 file of the FLM run is the Grid Point Weight Generator output for the fluid mass matrix. The values printed for the fluid mass depend on the fluid surface option chosen. For the ENCLOSED, FIXED, and RELATIVE options, the full fluid mass is included¹² as illustrated in Figure 4-17. In this case the fluid mass is 41.4418 lbf-sec²/in or 16,000 lbm, matching the value calculated based on the fluid volume multiplied by density. It is often appropriate to readjust the fluid density and rerun the FLK and FLM runs in order to achieve the correct fluid mass.

¹¹ The MPC coefficients are not required for either the NO_SLOSH_STD or NO_SLOSH_FAST options.

¹² For these options, the mass should be the same in all three directions. However, for complex geometry a small discrepancy in mass in the axial direction is often observed. This should be less than 1% of the total fluid mass.

O U T P U T F R O M G R I D P O I N T W E I G H T G E N E R A T O R						
REFERENCE POINT = 0						
M O						
* 4.144180E+01	3.553293E-15	-3.552714E-15	1.072920E-12	-9.289819E+02	5.312211E-15	*
* 3.553293E-15	4.144180E+01	1.551537E-14	9.289819E+02	-4.973799E-13	1.854528E-14	*
* -3.552714E-15	1.551537E-14	4.144180E+01	-7.234720E-13	-9.031956E-12	-4.440683E-14	*
* 1.072920E-12	9.289819E+02	-7.234720E-13	3.487495E+04	-2.671641E-12	2.585154E-13	*
* -9.289819E+02	-4.973799E-13	-9.031956E-12	-2.671641E-12	3.487495E+04	-5.363349E-13	*
* 5.312211E-15	1.854528E-14	-4.440683E-14	2.585154E-13	-5.363349E-13	4.370472E-15	*
S						
	* 1.000000E+00	0.000000E+00	0.000000E+00			*
	* 0.000000E+00	1.000000E+00	0.000000E+00			*
	* 0.000000E+00	0.000000E+00	1.000000E+00			*
DIRECTION						
MASS AXIS SYSTEM (S)	MASS	X-C.G.	Y-C.G.	Z-C.G.		
X	4.144180E+01	2.588979E-14	-1.281848E-16	-2.241654E+01		
Y	4.144180E+01	4.475017E-16	-1.200189E-14	-2.241654E+01		
Z	4.144180E+01	2.179431E-13	-1.745754E-14	-1.071547E-15		
I(S)						
	* 1.405039E+04	2.671641E-12	1.572056E-13			*
	* 2.671641E-12	1.405039E+04	4.172535E-13			*
	* 1.572056E-13	4.172535E-13	4.370472E-15			*
I(Q)						
	* 1.405039E+04					*
		1.405039E+04				*
			4.370472E-15			*
Q						
	* 1.000000E+00	0.000000E+00	0.000000E+00			*
	* 0.000000E+00	1.000000E+00	0.000000E+00			*
	* 0.000000E+00	0.000000E+00	1.000000E+00			*

Figure 4-17. Grid Point Weight Generator Output for ENCLOSED, FIXED, and RELATIVE options.

The output when using the NO_SLOSH_STD format will have different mass in different directions. This is because the sloshing mass is removed from the model in the lateral directions. The mass in the direction perpendicular to the fluid surface, however, will be the full mass as illustrated in Figure 4-18. In this case the mass in the Z direction (perpendicular to the fluid surface) is 41.4418 lbf-sec²/in as in the other cases, but the mass in the X and Y directions is 16.27371 lbf-sec²/in. This is the total mass of the fluid minus the sloshing mass.

```

O U T P U T   F R O M   G R I D   P O I N T   W E I G H T   G E N E R A T O R
                REFERENCE POINT =           0
                M O
*  1.627371E+01  2.460956E-15 -7.178286E-15  1.271205E-14 -4.555199E+00  3.826854E-15 *
*  2.460956E-15  1.627371E+01  4.911870E-15  4.555199E+00  2.453593E-14  1.055308E-14 *
* -7.178286E-15  4.911870E-15  4.144180E+01 -8.831824E-14 -8.992806E-14 -4.546347E-14 *
*  1.271205E-14  4.555199E+00 -8.831824E-14  1.693736E+00 -4.848899E-14  3.838238E-15 *
* -4.555199E+00  2.453593E-14 -8.992806E-14 -4.848899E-14  1.693736E+00 -4.015004E-15 *
*  3.826854E-15  1.055308E-14 -4.546347E-14  3.838238E-15 -4.015004E-15  1.191357E-15 *
                S
                *  1.000000E+00  0.000000E+00  0.000000E+00 *
                *  0.000000E+00  1.000000E+00  0.000000E+00 *
                *  0.000000E+00  0.000000E+00  1.000000E+00 *
DIRECTION
MASS AXIS SYSTEM (S)      MASS              X-C.G.              Y-C.G.              Z-C.G.
X                          1.627371E+01      7.811402E-16      -2.351555E-16      -2.799114E-01
Y                          1.627371E+01      6.484741E-16      1.507703E-15      -2.799114E-01
Z                          4.144180E+01      2.169984E-15      -2.131139E-15      -1.097044E-15
                I(S)
                *  4.186840E-01  4.848899E-14 -8.843101E-16 *
                *  4.848899E-14  4.186840E-01  2.943824E-15 *
                * -8.843101E-16  2.943824E-15  1.191357E-15 *
                I(Q)
                *  4.186840E-01 *
                *  4.186840E-01 *
                *  1.191357E-15 *
                Q
                *  1.000000E+00  0.000000E+00  0.000000E+00 *
                *  0.000000E+00  1.000000E+00  0.000000E+00 *
                *  0.000000E+00  0.000000E+00  1.000000E+00 *
    
```

Figure 4-18. Grid Point Weight Generator output for NO_SLOSH_STD option.

When using the NO_SLOSH_FAST option, the mass properties are not output in Grid Point Weight Generator format. Instead the rigid body mass matrix and masses are printed to the .f06 file in the format illustrated in Figure 4-19. The mass in the Z direction is 41.44180 lbf-sec²/in and the mass in the X and Y directions is 16.27371 lbf-sec²/in as in the case of the NO_SLOSH_STD option.

```

0      MATRIX MRIG      (GINO NAME 101 ) IS A DB  PREC      6 COLUMN X      6 ROW SQUARE
MATRIX.
OCOLUMN  1      ROWS      1 THRU      6      -----
ROW
1)      1.6274D+01  1.9054D-15 -6.5954D-15  1.8350D-14 -4.5552D+00  3.2207D-15
OCOLUMN  2      ROWS      1 THRU      6      -----
ROW
1)      2.2452D-15  1.6274D+01 -1.3808D-15  4.5552D+00  1.5453D-14  7.6360D-15
OCOLUMN  3      ROWS      1 THRU      6      -----
ROW
1)      -7.4107D-15 -6.1045D-15  4.1442D+01 -3.6837D-14 -2.7311D-14 -4.5336D-14
OCOLUMN  4      ROWS      1 THRU      6      -----
ROW
1)      1.7978D-14  4.5552D+00 -3.9960D-14  1.6937D+00 -3.3057D-16  1.6208D-15
OCOLUMN  5      ROWS      1 THRU      6      -----
ROW
1)      -4.5552D+00  1.5465D-14 -2.7799D-14 -6.6277D-16  1.6937D+00 -3.8757D-16
OCOLUMN  6      ROWS      1 THRU      6      -----
ROW
1)      3.2207D-15  7.6360D-15 -4.5336D-14  1.6208D-15 -3.8757D-16  5.8951D-28
0THE NUMBER OF NON-ZERO TERMS IN THE DENSEST COLUMN =      6
0THE DENSITY OF THIS MATRIX IS 100.00 PERCENT.
^^^FLUID MASS IN THE BASIC X DIRECTION IS      1.627371E+01
^^^FLUID MASS IN THE BASIC Y DIRECTION IS      1.627371E+01
^^^FLUID MASS IN THE BASIC Z DIRECTION IS      4.144180E+01
    
```

Figure 4-19. Mass Property Output for NO_SLOSH_FAST Option.

The output of the _FLM run depends on the option chosen. For the NO_SLOSH_FAST option it is an OUTPUT2 file with the PKLL and AGL matrices for input into the coupled modes run. For the NO_SLOSH_STD and ENCLOSED options, it is a single mass matrix FMAA written to pressure database as illustrated in .

KEY NUMBER =	689	QUALIFIER NAME AND VALUE
		ZNAME =FMAA1
		ZUZR1 = 0
		ZUZR2 = 0
		ZUZR3 = 0

Figure 4-20. A single mass matrix is written to the database for the NO_SLOSH_STD and ENCLOSED options.

For the FIXED and RELATIVE options, the mass matrix is written in three partitions as illustrated in Figure 4-21.

KEY NUMBER =	691	QUALIFIER NAME AND VALUE
		ZNAME =FMOO
		ZUZR1 = 0
		ZUZR2 = 0
		ZUZR3 = 0
KEY NUMBER =	692	QUALIFIER NAME AND VALUE
		ZNAME =FMAO
		ZUZR1 = 0
		ZUZR2 = 0
		ZUZR3 = 0
KEY NUMBER =	693	QUALIFIER NAME AND VALUE
		ZNAME =FMAA1
		ZUZR1 = 0
		ZUZR2 = 0
		ZUZR3 = 0
KEY NUMBER =	694	QUALIFIER NAME AND VALUE
		ZNAME =UTOPG
		ZUZR1 = 0
		ZUZR2 = 0
		ZUZR3 = 0

Figure 4-21. Three partitions of the mass matrix are written to the database for the FIXED and RELATIVE options.

If any pressure recovery grids were requested in the FLK run, the UTOPG pressure recovery matrix is also written to the database as illustrated in Figure 4-22. The rows of this matrix are all the pressure DOF on the boundary of the fluid and the columns are the superelement DOF.

KEY NUMBER =	694	QUALIFIER NAME AND VALUE
		ZNAME =UTOPG
		ZUZR1 = 0
		ZUZR2 = 0
		ZUZR3 = 0

Figure 4-22. The UTOPG pressure recovery matrix is written to the database if any pressure recovery grids were selected.

In addition the UTOP pressure recovery matrix is written in OUTPUT4 format to the file press.op4. The rows of this matrix are the requested pressure recovery GRIDS and the columns are the superelement DOF. The pressure is recovered as follows:

$$p = [UTOP]\{\ddot{u}\}$$

4.1.5. FSK - Free Surface Stiffness Matrix Run

For the FIXED and RELATIVE options, the FSK run is also prepared by HYDRO. The FSK run generates the area matrix relating the boundary pressure grids at the free surface to the free surface grids. The area matrix was used to generate the free surface stiffness matrix (“gravity stiffness”) needed to calculate slosh modes.

No changes are needed to the FSK input deck written by the HYDRO program. The FSK run stores the free surface stiffness matrix (FKGG) in DMIG format into the database, as illustrated in Figure 4-23.

KEY NUMBER =	696	QUALIFIER NAME AND VALUE	
		ZNAME	=FKGGDMIG
		ZUZR1	= 0
		ZUZR2	= 0
		ZUZR3	= 0

Figure 4-23. The FSK run stores the FKGGDMIG matrix in the database.

4.1.6. HYDRO “MPC” Run

An additional run of the HYDRO program using the “MPC” option is required for the ENCLOSED, FIXED, and RELATIVE options. This takes the coefficients required to enforce incompressibility written to the .pch file from the FLM run and converts them to an MPC card.

The significant items entered into the HYDRO “MPC” run were as follows:

- “MPC” mode
- Name of the FLM .PCH file (e.g. fixed_flm.pch)
- Minimum MPC coefficient to write¹³ (default is usually satisfactory)
- Dependent grid ID number = 30000 (the center grid of the free surface)
- Dependent DOF = 3 (the normal displacement of free surface grid 30000)
- The name of the MPC bulk data file to be written (fixed_flm_mpc.blk)
- The superelement ID number = 10 (used for the MPC set ID number)

For the FIXED and RELATIVE options, the MPC cards for incompressibility must be included in the SUP run. For the ENCLOSED option, the MPC card is included in the structural coupling run¹⁴.

¹³ Entering a minimum coefficient reduces the size of the MPC equation by eliminating near zero values. The default value is 1×10^{-5} times the maximum value. This is satisfactory for most problems.

¹⁴ The incompressibility equation is not required for either of the NO_SLOSH options.

4.1.7. SUP - Fluid Superelement Run

A SUP run is created for all options other than NO_SLOSH_FAST, though the format depends on the Superelement output option. This run takes the mass and stiffness matrices generated in the FLM and FSK runs and converts them to a NASTRAN superelement. The form of the superelement depends on the Superelement output option. If the fluid includes a sloshing free surface (FIXED or RELATIVE), the SUP run also calculates the slosh modes and associated modal effective mass. The following items are placed in the SUP input deck.

- For external superelements, an EXTSEOUT Case Control card and an associated ASSIGN card are written.
- For the FIXED and RELATIVE options, generalized coordinates are added for the slosh modes using SPOINT cards and either an SEQSET1 card, a bulk data superelement, or a QSET1 card for an external superelement.
- For a bulk data superelement, the free surface nodes are identified on SESET cards and the wetted surface nodes on CSUPEXT cards. For an external superelement, the wetted surface nodes are identified on BSET1 cards.
- For the FIXED and RELATIVE options, an EIGR card using the Automated Householder method (AHOU) is added to calculate the first 25 slosh modes.
- The MPC card defining the incompressibility constraint is added using INCLUDE 'fixed_flm_mpc.blk'. The user can edit this filename if necessary.

Two databases are used by the SUP run. The first database is a new database which is used to store the data blocks for the fluid superelement model. The second database is the fluid model one used by the FLK, FLM, and FSK runs. This split database technique minimizes the disk storage requirements for subsequent processing of the fluid superelement. The fluid model database used by the FLK, FLM, and FSK runs can be deleted following the SUP run.

For the DMIGOP2 and MATOP4 external superelement options, the matrices are written to an external file, which is identified in an ASSIGN statement. In these cases, as well as the DMIGPCH formats, a .pch file is also written that contains the external superelement (BEGIN SUPER) definition.

The important activities performed by the SUP run for the example problem were as follows:

- The fluid mass matrix formed in the FLM run is arranged into a final form compatible with the grids in the SUP run.
- The fluid mass matrix properties are calculated and reported in the Grid Point Weight Generator output. The GPWG output from the SUP run should be **identical** to the output from the FLM run.

- The free surface stiffness matrix formed in the FSK run is arranged into final form compatible with the grids in the SUP run for the FIXED and RELATIVE options.
- The multipoint constraint (MPC) equation for incompressibility is imposed for the ENCLOSED, FIXED, and RELATIVE options.
- Slosh modes are calculated for the FIXED and RELATIVE options. By default, the first 25 slosh modes are calculated.
- The final stiffness and mass matrices are generated for the fluid superelement. A null KAA matrix is created to define zero static stiffness for the fluid model and to satisfy superelement requirements that a KAA matrix be present for the ENCLOSED and NO_SLOSH_STD options. The MAA matrix was created from the fluid mass matrix and static reduction. KLAA and MLAA were assembled using the slosh modes.
- If one of the external superelement options is chosen, the appropriate files are output.
- Data recovery is performed to recover the slosh mode shapes and modal effective mass is calculated. The modal effective mass results are output to the .f06 using the standard NASTRAN format.

The modal effective mass fractions for the first fifty slosh modes are illustrated in Figure 4-24. In each direction, NASTRAN lists the individual mass fraction and a cumulative sum. For this example, the first two slosh modes at 0.506 Hz have modal effective mass fractions of 57.0% in one direction and 1.3% in the other. The only other modes with greater than 1% modal effective mass are modes 10 and 11 at 0.964 Hz with modal effective mass fractions of 1.3%. The pair of modes with the third largest modal effective mass are modes 23 and 24 at 1.305 Hz, but these have less than a 1% fraction. The total modal effective mass for all of the slosh modes is 60.7%, meaning that 60.7% of the total fluid mass is involved with low frequency sloshing motion, and 39.3% is not. That implies that the lateral mass properties for the NO_SLOSH options should be approximately 39.3% of the total fluid mass. This is $0.393 \times 41.4418 = 16.2966$ lbf-sec²/in, which is very close to the calculated value of 16.2737 lbf-sec²/in.

For most applications, the first two pairs of slosh modes are sufficient to represent the fluid slosh (modes at 0.506 and 0.964 Hz for this example). In addition, studies have shown that the first axial mode should also be retained (0.797 Hz for this example). Slosh modes are only calculated for the FIXED and RELATIVE options.

MODAL EFFECTIVE MASS FRACTION							
MODE NO.	FREQUENCY	T1		T2		T3	
		FRACTION	SUM	FRACTION	SUM	FRACTION	SUM
1	<u>5.062593E-01</u>	<u>1.297016E-02</u>	1.297016E-02	<u>5.704373E-01</u>	5.704373E-01	1.078537E-30	1.078537E-30
2	<u>5.062593E-01</u>	<u>5.704373E-01</u>	5.834074E-01	<u>1.297016E-02</u>	5.834074E-01	2.691052E-29	2.798906E-29
3	6.846851E-01	1.552514E-29	5.834074E-01	2.849645E-31	5.834074E-01	2.840684E-31	2.827313E-29
4	6.846851E-01	1.525872E-29	5.834074E-01	3.028808E-28	5.834074E-01	2.170009E-31	2.849013E-29
5	<u>7.974601E-01</u>	1.233062E-28	5.834074E-01	1.921427E-30	5.834074E-01	2.974047E-30	3.146417E-29
6	8.236362E-01	4.816121E-30	5.834074E-01	4.971105E-30	5.834074E-01	1.902101E-30	3.336628E-29
7	8.236362E-01	1.295596E-30	5.834074E-01	8.901722E-30	5.834074E-01	8.778304E-31	3.424411E-29
8	9.478566E-01	4.681830E-29	5.834074E-01	5.822181E-29	5.834074E-01	5.282532E-32	3.429693E-29
9	9.478566E-01	3.238991E-31	5.834074E-01	2.544682E-29	5.834074E-01	7.585110E-30	4.188204E-29
10	<u>9.636134E-01</u>	<u>1.285864E-02</u>	5.962660E-01	<u>2.656884E-03</u>	5.860643E-01	4.684576E-30	4.656662E-29
11	<u>9.636134E-01</u>	<u>2.656884E-03</u>	5.989230E-01	<u>1.285864E-02</u>	5.989230E-01	3.186409E-30	4.975302E-29
12	1.066545E+00	5.889817E-31	5.989230E-01	1.095011E-31	5.989230E-01	1.512929E-30	5.126596E-29
13	1.066545E+00	3.886856E-29	5.989230E-01	3.012442E-29	5.989230E-01	3.870963E-30	5.513692E-29
14	1.100664E+00	3.552001E-30	5.989230E-01	2.289398E-32	5.989230E-01	2.915512E-31	5.542847E-29
15	1.100664E+00	8.570406E-30	5.989230E-01	6.492871E-30	5.989230E-01	1.727864E-31	5.560125E-29
16	1.144128E+00	1.262682E-30	5.989230E-01	5.293579E-31	5.989230E-01	1.041758E-28	1.597771E-28
17	1.184522E+00	3.438267E-31	5.989230E-01	9.569861E-30	5.989230E-01	1.921438E-30	1.616985E-28
18	1.184522E+00	9.962396E-31	5.989230E-01	8.946802E-30	5.989230E-01	4.185433E-30	1.658840E-28
19	1.225332E+00	1.794432E-31	5.989230E-01	1.682098E-31	5.989230E-01	4.138501E-30	1.700225E-28
20	1.225332E+00	9.958014E-30	5.989230E-01	1.137127E-30	5.989230E-01	1.674197E-31	1.701899E-28
21	1.304134E+00	6.447743E-27	5.989230E-01	4.686552E-27	5.989230E-01	1.153669E-29	1.817266E-28
22	1.304134E+00	1.892847E-28	5.989230E-01	3.366656E-26	5.989230E-01	3.380244E-31	1.820646E-28
23	<u>1.304870E+00</u>	<u>8.822566E-04</u>	5.998055E-01	<u>3.784423E-03</u>	6.027074E-01	5.874356E-30	1.879389E-28
24	<u>1.304870E+00</u>	<u>3.784423E-03</u>	6.035900E-01	<u>8.822566E-04</u>	6.035900E-01	4.777724E-30	1.927167E-28
25	1.348212E+00	1.879819E-30	6.035900E-01	5.939555E-33	6.035900E-01	5.713594E-30	1.984303E-28
26	1.348212E+00	2.289398E-30	6.035900E-01	1.316847E-30	6.035900E-01	1.519128E-30	1.999494E-28
27	1.425056E+00	2.409167E-32	6.035900E-01	4.182581E-33	6.035900E-01	2.318786E-29	2.231373E-28
28	1.425056E+00	1.519143E-29	6.035900E-01	1.086413E-30	6.035900E-01	1.620910E-29	2.393464E-28
29	1.444922E+00	2.429285E-30	6.035900E-01	5.366804E-30	6.035900E-01	1.254960E-29	2.518960E-28
30	1.444922E+00	7.287729E-31	6.035900E-01	8.344713E-32	6.035900E-01	9.558692E-32	2.519915E-28
31	1.473208E+00	1.595868E-30	6.035900E-01	3.639891E-32	6.035900E-01	3.786601E-30	2.557782E-28
32	1.473208E+00	8.382120E-30	6.035900E-01	1.849642E-31	6.035900E-01	5.883709E-32	2.558370E-28
33	1.492184E+00	2.373661E-31	6.035900E-01	7.641587E-31	6.035900E-01	7.537135E-30	2.633741E-28
34	1.542882E+00	6.293576E-31	6.035900E-01	2.136295E-30	6.035900E-01	4.254760E-29	3.059217E-28
35	1.542882E+00	1.809552E-30	6.035900E-01	1.295596E-30	6.035900E-01	1.496033E-29	3.208821E-28
36	1.576986E+00	2.098652E-30	6.035900E-01	5.913165E-30	6.035900E-01	4.325261E-31	3.213146E-28
37	1.576986E+00	1.346387E-30	6.035900E-01	4.107457E-30	6.035900E-01	6.894373E-31	3.220040E-28
38	1.602213E+00	3.141583E-31	6.035900E-01	8.282556E-30	6.035900E-01	5.970304E-30	3.279743E-28
39	1.602213E+00	1.130970E-31	6.035900E-01	2.812367E-31	6.035900E-01	2.860560E-30	3.308349E-28
40	1.647240E+00	5.026533E-32	6.035900E-01	4.696237E-30	6.035900E-01	3.189457E-29	3.627295E-28
41	1.647240E+00	2.506497E-28	6.035900E-01	8.729305E-29	6.035900E-01	1.788563E-29	3.806151E-28
42	1.665575E+00	3.804302E-04	6.039703E-01	2.026315E-03	6.056163E-01	3.547705E-29	4.160921E-28
43	1.665575E+00	2.026315E-03	6.059967E-01	3.804302E-04	6.059967E-01	1.469920E-29	4.307913E-28
44	1.703785E+00	2.315209E-29	6.059967E-01	6.817096E-29	6.059967E-01	2.101764E-29	4.518090E-28
45	1.703785E+00	8.214450E-28	6.059967E-01	9.756904E-29	6.059967E-01	6.242723E-31	4.524333E-28
46	1.721696E+00	4.602516E-29	6.059967E-01	1.200892E-29	6.059967E-01	1.069064E-28	5.593396E-28
47	1.721696E+00	3.260432E-28	6.059967E-01	1.505676E-28	6.059967E-01	4.320519E-30	5.636601E-28
48	1.735862E+00	2.432842E-29	6.059967E-01	3.540136E-31	6.059967E-01	1.006866E-28	6.643467E-28
49	1.735862E+00	1.085065E-28	6.059967E-01	2.879066E-29	6.059967E-01	1.126683E-29	6.756136E-28
50	1.749068E+00	8.276119E-29	6.059967E-01	2.198469E-29	6.059967E-01	7.154508E-30	6.827681E-28

Figure 4-24. Modal Effective Mass Fractions for First 50 Modes of Hemisphere Example

To check the accuracy of the slosh modes, exact solutions [8,9] were calculated for the fundamental lateral and axial slosh modes. The results are summarized in Table 4-2.

Table 4-2. Comparison of slosh mode frequencies.

MODE DESCRIPTION	THEORY	HYDRO	ERROR
1st Lateral Slosh Mode	0.504	0.506	0.40%
1st Axial Slosh Mode	0.782	0.797	1.92%
2nd Lateral Slosh Mode	0.928	0.964	3.88%
2nd Axial Slosh Mode	1.067	1.144	7.22%
3rd Lateral Slosh Mode	1.178	1.305	10.78%

This shows excellent accuracy for the fundamental lateral slosh mode. The accuracy of the first axial and second lateral slosh modes is reasonable (less than 5% error). The accuracy of the higher modes is fair to poor. If better accuracy for the higher modes is required, a finer fluid mesh would be needed. The effect of the fluid mesh on the accuracy of the slosh modes is discussed in more detail in Section 5.1.

4.1.8. Coupled Hydroelastic Model

HYDRO also creates a template for the structural coupling (CPL) run. The template requires some editing to add the structural model and optionally to change the parameters for the run. The data written to this deck depends on the fluid and SE options chosen and is summarized in Table 4-3 for bulk data superelements and the NO_SLOSH_FAST option and Table 4-4 for external superelement options.

Table 4-3. Data written to CPL runs for different options with standard superelements.

Data	ENCLOSE D	FIXE D	NO_SLOSH_ST D	NO_SLOSH_FAS T	RELATIV E
CSUPEXT Cards	Yes	Yes	Yes	No	Yes
hydro_cpl Alter	No	No	No	Yes	No
Free Surface GRIDs	No	Yes	No	No	Yes
Dummy interior GRID	Yes	No	Yes	No	No
SESET Cards	Yes	Yes	Yes	No	Yes
QSET Cards	No	No	No	Yes	No
SEQSET Cards	No	Yes	No	No	Yes
Dummy interior PLOTTEL	Yes	Yes	Yes	No	Yes
Surface Reference GRID	No	No	No	No	Yes

Table 4-4. Data written to CPL runs for different options with external superelements.

Data	DMIGPCH	DMIGOP2	DMIGD B	MATDB	MATOP 4	DMIG Only
DBLOCATE	No	No	Yes	Yes	No	No
INPUTT2	No	Yes	No	No	No	No
INPUTT4	No	No	No	No	Yes	Yes
hydro_scale Alter	Yes	Yes	Yes	Yes	Yes	No
K2GG and M2GG	Yes	No	No	No	No	Yes
.asm file	Yes	Yes	Yes	Yes	Yes	No
.pch file	Yes	Yes	Yes	Yes	Yes	Yes
FMASS parameter	Yes	Yes	Yes	Yes	Yes	No
GRAV parameter	Yes	Yes	Yes	Yes	Yes	No

The CPL input deck template for the FIXED option with the bulk data superelement format is illustrated in Figure 4-25. The only modification required for this deck is to include the structural model of the tank. Decks for the other options with a bulk data superelement are similar.

```

ASSIGN MASTER='system.master',DELETE
ASSIGN DBALL='system.dball',DELETE
$
ASSIGN FLUID='fixed.master'
DBLOCATE DATABLK=* LOGI=FLUID WHERE(SEID=10 or PEID=10)
DBDIR
$
ID      HYDRO,COUPLED
SOL     103
DIAG    8 $      Print matrix trailers
$
CEND
TITLE = HYDRO COUPLED SOLUTION
SUBTITLE = FIXED OPTION
$
ECHO = NONE $ Do not echo the bulk data deck
$
SET 1000 = 0
SEALL = 1000
DISP(PLOT) = ALL      $ Recover mode shapes
$
SUBCASE      10
SUPER        10
LABEL = FLUID SUPERELEMENT
MPC          =      10 $ Incompressibility
METHOD       =      10 $ Calculate slosh modes
MEFFMASS(FRACSUM) = YES $ Recover effective mass
$
SUBCASE 9999
LABEL = RESIDUAL STRUCTURE
METHOD      = 100
WEIGHTCHECK = YES
SPC         = 1
$
BEGIN BULK
$
$  PARAMETERS
$
PARAM      DBDICT      2
PARAM      USETPRT     0
PARAM      WTMASS 0.00259
PARAM      POST        -2
PARAM      GRDPNT      0
$
$ method for system modes
EIGRL      100      100.
$
$ placeholder for structural model bulk data
INCLUDE 'structure.blk'
$
$  Interior (fluid free surface) grids
$
GRID       30000      1 0.00000 0.00000 0.00000      0 12456
          :
GRID       32306      1 48.0000 345.000 0.00000      1 12456
$
SESET      10 30000 30001 30003 30004 30005 30006 30101
          :
SESET      10 32305 32306
$
CSUPEXT    10 20001 20002 20007 20008 20009 20010 20011
          :
CSUPEXT    10 22310 22311 22312 22313
$
$  "Dummy" element
$
PLOTTEL    10 20001 20002
SEELT      10      10
$
INCLUDE 'mpc.blk'
$
$  Superelement q-set dof for component (slosh) modes
$

```

```

GRID      99001
:
GRID      99020
SEQSET1   10 123456 99001 THRU 99020
$
$
$ placeholder for SPCs to remove all but first 3 slosh modes (for example)
SPC1      1    456 99001
SPC1      1 123456 99002 THRU 99020
$
$ Eigensolution data for component (slosh) modes
$
EIGR      10    GIV    0.0    2.5
$
ENDDATA

```

Figure 4-25. Coupled fluid-structure template written by HYDRO for the hemisphere example.

The hemisphere model was coupled to the tank illustrated in Figure 4-1, and modes were calculated using the different options. The structural frequencies for the various options with the tank fixed at the top are summarized Table 4-5. The frequencies with an enclosed fluid are quite different because the fluid surface is covered with a thin plate. The fixed and relative results are identical because the structure is fixed to ground along with the relative reference node. The NO_SLOSH_STD and NO_SLOSH_FAST options do not include the slosh modes but do a good job of approximating the effect of the fluid on the structural modes. The first few lateral frequencies are within ~2%. There is an 8% frequency error in the first axial mode using the "fast" option, presumably due to the fact that there are very few axial modes of the "dry" tank used to reduce the fluid mass matrix.

Table 4-5. Comparison of structural frequencies for different fluid options.

Description	ENCLOSE D	FIXED	RELATIV E	NOSLOSH_STD	Error	NOSLOSH_FAST	Error
1st Lateral	21.970	23.380	23.380	23.524	1%	23.680	1%
2nd Lateral	21.970	23.380	23.380	23.524	1%	23.680	1%
3rd Lateral	22.289	33.826	33.826	34.286	1%	34.287	1%
4th Lateral	22.289	33.826	33.826	34.286	1%	34.287	1%
5th Lateral	26.504	35.019	35.019	35.323	1%	35.323	1%
6th Lateral	26.504	35.019	35.019	35.323	1%	35.323	1%
1st Axial	33.140	35.161	35.161	35.196	0%	37.964	8%
7th Lateral	27.561	35.659	35.659	36.490	2%	36.491	2%
8th Lateral	27.561	35.659	35.659	36.490	2%	36.491	2%
9th Lateral	28.829	38.204	38.204	38.440	1%	38.440	1%
10th Lateral	28.829	38.204	38.204	38.440	1%	38.440	1%
11th Lateral	30.401	40.721	40.721	41.892	3%	41.893	3%
12th Lateral	30.401	40.721	40.721	41.892	3%	41.893	3%
13th Lateral	37.010	41.682	41.682	42.492	2%	42.496	2%
14th Lateral	37.010	41.682	41.682	42.492	2%	42.496	2%
2nd Axial	35.383	43.294	43.294	43.499	0%	43.499	0%
15th Lateral	39.585	44.179	44.179	52.257	18%	52.258	18%
16th Lateral	39.585	44.179	44.179	52.257	18%	52.280	18%

The input deck template for the DMIGOP2 external superelement output option is listed in Figure 4-26. Templates for other external superelement options are similar. To include multiple fluid superelements, multiple INPUTT2 files will need to be assigned and the UNIT numbers on the SEBULK card in the *.asm files will need to be updated to correspond to the correct values.

```

$
ASSIGN MASTER='system.master',DELETE
ASSIGN DBALL='system.dball',DELETE
$
ASSIGN INPUT2='hydroex.op2' UNIT=11
$
ID          HYDRO,COUPLED
SOL         103
DIAG        8 $      Print matrix trailers
$
$
CEND
TITLE = HYDRO COUPLED SOLUTION
SUBTITLE = FIXED OPTION
$
ECHO = NONE $ Do not echo the bulk data deck
$
DISP(PLOT) = ALL      $ Recover mode shapes
$
WEIGHTCHECK(SET=G) = YES
MEFFMASS(FRACSUM) = YES $ Recover effective mass
$
METHOD      = 100
SPC         = 1
$
BEGIN BULK
$
$  PARAMETERS
$
PARAM       DBDICT          2
PARAM       USETPRT         0
PARAM       WTMASS 0.00259
PARAM       POST            -1
PARAM       GRDPNT          0
$
$ method for system modes
EIGRL       100             100.
$
$ placeholder for structural model bulk data
INCLUDE 'structure.blk'
$
$ Bulk data for CMS
$
INCLUDE 'hydroex.asm'
$
$ placeholder for SPCs to remove all but first 3 slosh modes (for example)
SPC1        1              0 100004   THRU 100025
$
INCLUDE 'hydroex_sup.pch'
$
ENDDATA

```

Figure 4-26. External DMIGOP2 SE coupled fluid-structure template.

The template for the DMIG Only output option is listed in Figure 4-27. In this case, the DMIG matrices representing the fluid are referenced directly on K2GG and M2GG cards in case control, and there are no superelement cards.

```

$
ASSIGN MASTER='system.master',DELETE
ASSIGN DBALL='system.dball',DELETE
$
ID      HYDRO,COUPLED
SOL     103
DIAG    8 $      Print matrix trailers
$
$
CEND
TITLE = HYDRO COUPLED SOLUTION
SUBTITLE = FIXED OPTION
$
ECHO = NONE $ Do not echo the bulk data deck
$
DISP(PLOT) = ALL      $ Recover mode shapes
$
WEIGHTCHECK(SET=G) = YES
MEFFMASS(FRACSUM) = YES $ Recover effective mass
$
METHOD      = 100
SPC         = 1
$
K2GG = KAAX
M2GG = MAAX
$
BEGIN BULK
$
$  PARAMETERS
$
PARAM      POST      -1
PARAM      GRDPNT    0
$
$  method for system modes
EIGRL      100          100.
$
$  placeholder for structural model bulk data
INCLUDE 'structure.blk'
$
$  DMIG cards for fluid
%
SPOINT     100001      THRU 10002
INCLUDE 'hydroex_sup.pch'
$
ENDDATA

```

Figure 4-27. DMIG Only coupled fluid-structure template

The NO_SLOSH_FAST option does not use a superelement to represent the fluid. In this case, the deck is different, and this is covered in greater detail in Section 4.2.5.

4.2. **Motorcycle Tank Stress Model**

The second example problem is the motorcycle tank illustrated in Figure 4-28, used for dynamic stress and fatigue analysis. The mesh of the tank was partitioned at the fluid surface but otherwise was developed for the purpose of stress analysis, with very small elements in regions of high stress. The structural model had a total of 10,844 nodes and 11,197 elements.

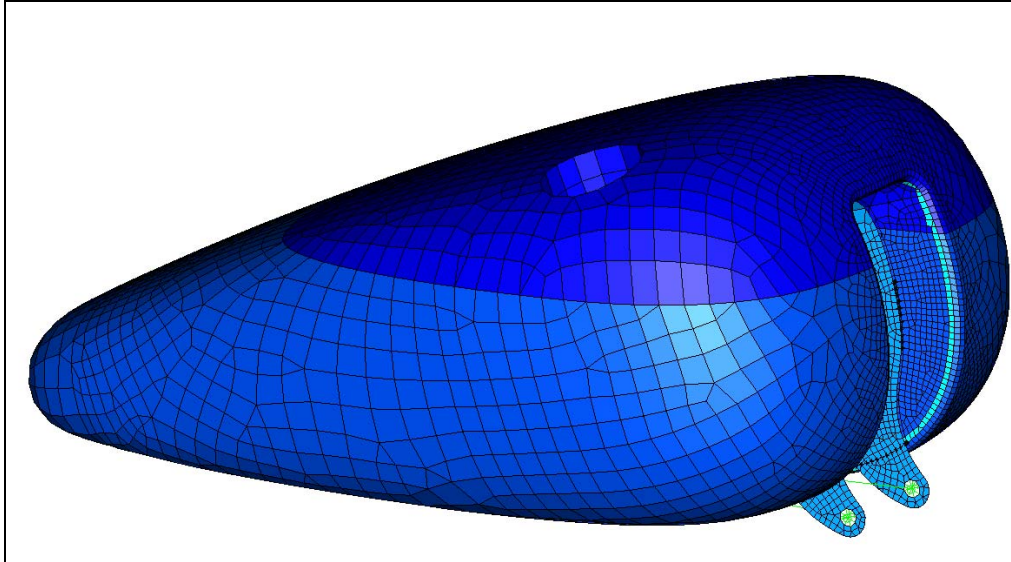

Figure 4-28. Outer shell of motorcycle tank example.

4.2.1. I-deas Hydroelastic Finite Element Model

To develop the fluid model, the wetted surface of the tank was extracted along with the meshed free surface, as illustrated in Figure 4-29. This consists of 8,911 nodes and 8,980 elements.

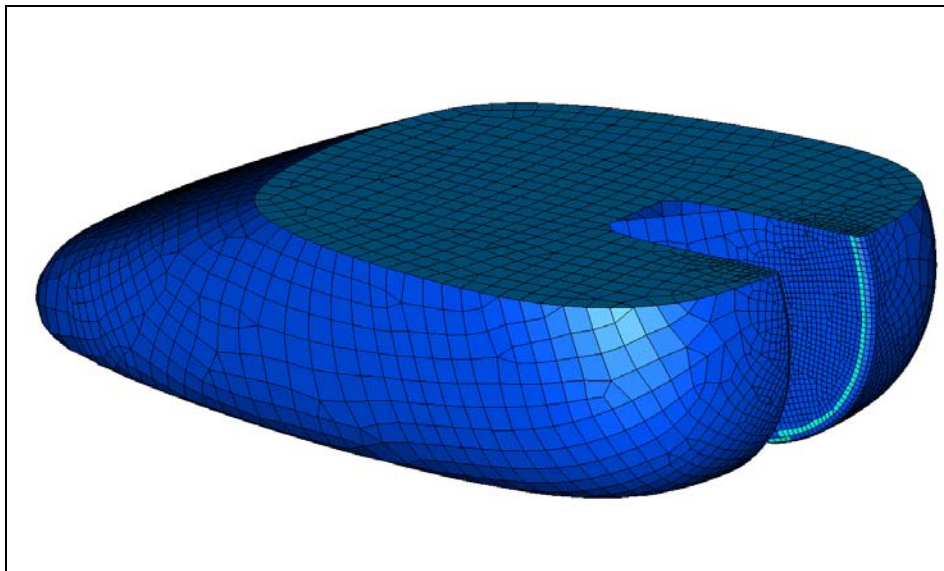

Figure 4-29. Fluid surface elements (wetted tank and free surface).

The fluid mesh was created using a free (tetrahedral) mesh on the wetted and free surface geometry. Since the surfaces were already meshed, the fluid mesh shared the same node

locations¹⁵, as illustrated in Figure 4-30. Note that while the surface and fluid volume models must have compatible meshes in the sense that the node locations on the surface are coincident, the elements need not be compatible. In this case, the surface is meshed largely with quadrilateral elements for accurate stress recovery, while the fluid volume is entirely meshed with tetrahedral elements. The total volume of the fluid solid elements is 1,032 in³.

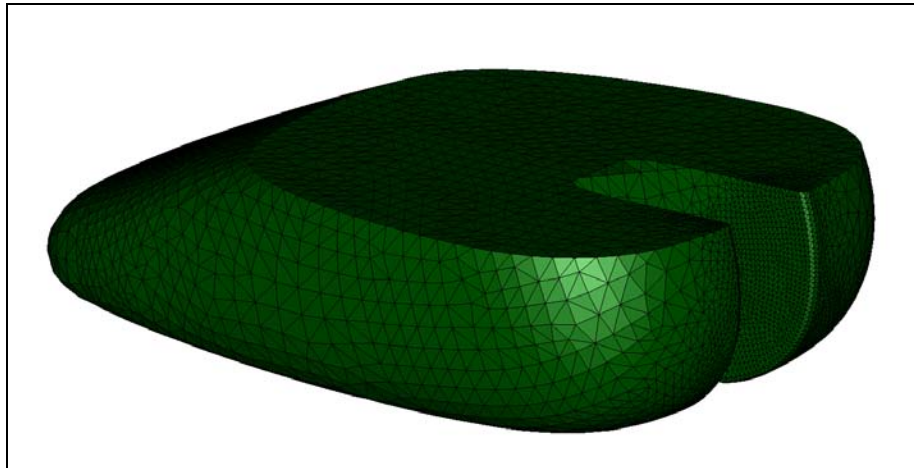

Figure 4-30. Fluid surface elements (wetted tank and free surface).

The hydroelastic model is exported in NASTRAN format for input into the HYDRO program. It consists of the wetted surface of the tank, the free surface of the fluid, and the volume elements representing the fluid. The model has the following characteristics:

1. The three parts of the model (wetted surface, free surface, and fluid) do not share any nodes.
2. All the nodes on the surface of the fluid are coincident with nodes on either the wetted or free surface within a user-defined tolerance (0.01" in this case). This tolerance must be smaller than the smallest element size in the model.
3. The wetted and free surface elements must have consistent element normals (pointing out in this case).
4. The free surface elements use a unique PID (three in this case).
5. The nodes on the free surface have a displacement coordinate system with the Z axis oriented out of the free surface.

4.2.2. HYDRO "Prep" Run

In this case, only the NO_SLOSH_FAST option is feasible, so only this option is presented. The inputs are summarized in Table 4-6.

¹⁵ While the fluid surface and fluid volume nodes must be coincident on the surface, they are not the same nodes. The fluid volume does not share any nodes with the wetted structure or free surface. In this case, this required making a copy of the fluid and deleting the original version which did share nodes on the surface.

Table 4-6. Inputs to HYDRO run for motorcycle tank example.

1	NASTRAN bulk file	hydroex.hfem
2	free surface?	Y
3	surface option	no_slosh_fast
6	free surface PID	5
7	coincident node tolerance	.01
8	fluid type or density	water
13	NASTRAN version number	V2001
14	NASTRAN buffer size	default
15	pressure model database	fast_P
17	fluid stiffness input file (FLK)	fast_flk.dat
18	fluid mass input file (FLM)	fast_flm.dat
19	Output2 file written by FLM run	fast_flm.ou2
22	template for coupled system run (CPL)	fast_cpl.dat

The input decks for the command line version of HYDRO are presented in Figure 4-31, and the GUI inputs are illustrated in Figure 4-32.

```

PREP
tank.hfem
Y
NO_SLOSH_FAST
3
0.01
gasoline
v2001

S:\tank_P
S:\tank
fast_flk.dat
fast_flm.dat
fast_flm.ou2
fast_cplnew.dat

```

Figure 4-31. HYDRO input for motorcycle tank example.

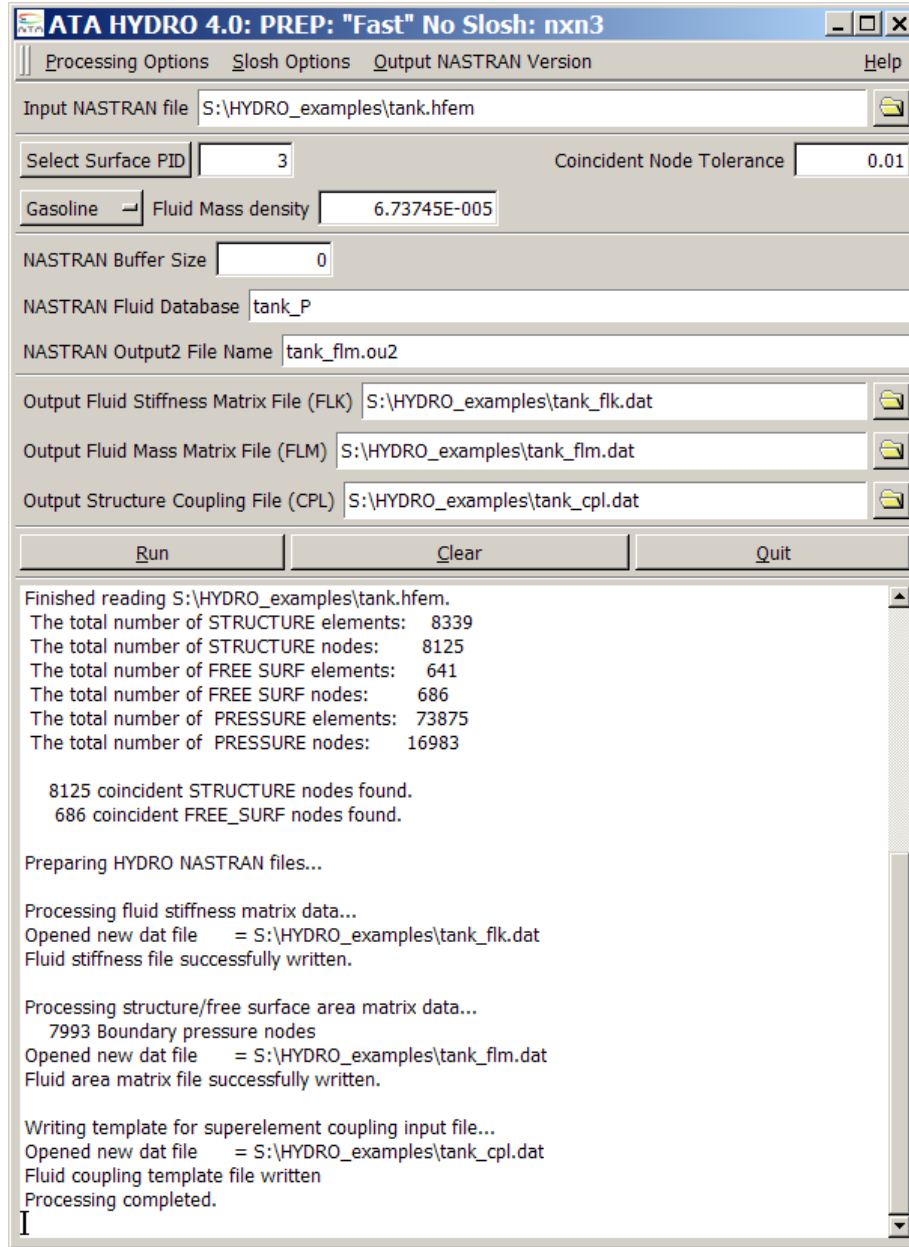

Figure 4-32. HYDRO GUI input for fluid hemisphere example with ENCLOSED option.

The HYDRO runs creates the tank_flk, tank_flm, and tank_cpl.dat NASTRAN input files.

4.2.3. FLK - Fluid Stiffness (Inertance) Matrix

The FLK run generates the fluid inertance (stiffness) matrix associated with the fluid pressure model. This run does not require any editing before executing. The .f06 file should be checked for FATAL errors. For the NO_SLOSH_FAST option, the only data stored in the database is the PKLL matrix as illustrated in Figure 4-33.

```

KEY NUMBER = 687          QUALIFIER NAME AND VALUE
                        ZNAME =PKLL
                        ZUZR1 =          0
                        ZUZR2 =          0
                        ZUZR3 =          0

END OF DIRECTORY PRINT
1                               * * * END OF JOB * * *
    
```

Figure 4-33. NASTRAN .f06 file output for motorcycle tank FLK run.

4.2.4. FLM - Fluid Mass Matrix Run

The rigid body mass matrix and masses for the motorcycle example are illustrated in Figure 4-34. In this case, the Y axis is perpendicular to the fluid free surface. The mass in the Y direction is .06956879 lbf-sec²/in. This is very close to the volume times the density 1032*6.73726E-5= 0.06953 lbf-sec²/in. The masses in the X (.03342353 lbf-sec²/in) and Z directions (.04606164 lbf-sec²/in) is somewhat less since this does not include the sloshing mass.

```

0      MATRIX MRIG      (GINO NAME 101 ) IS A DB  PREC          6 COLUMN X          6 ROW SQUARE
MATRIX.
OCOLUMN      1      ROWS      1 THRU      6      -----
ROW
1)  3.3424D-02 -4.5074D-06  1.7114D-04  2.3157D-03 -7.1927D-03 -6.7209D-01
OCOLUMN      2      ROWS      1 THRU      6      -----
ROW
1)  -4.5074D-06  6.9569D-02  9.2443D-07  7.3474D-03 -3.3366D-05  1.4620D+00
OCOLUMN      3      ROWS      1 THRU      6      -----
ROW
1)  1.7114D-04  9.2443D-07  4.6062D-02  8.4210D-01 -1.0003D+00 -8.1262D-04
OCOLUMN      4      ROWS      1 THRU      6      -----
ROW
1)  2.3157D-03  7.3474D-03  8.4210D-01  1.6472D+01 -1.8166D+01  1.3261D-01
OCOLUMN      5      ROWS      1 THRU      6      -----
ROW
1)  -7.1927D-03 -3.3366D-05 -1.0003D+00 -1.8166D+01  2.2804D+01  1.1003D-01
OCOLUMN      6      ROWS      1 THRU      6      -----
ROW
1)  -6.7209D-01  1.4620D+00 -8.1262D-04  1.3261D-01  1.1003D-01  4.5759D+01
0THE NUMBER OF NON-ZERO TERMS IN THE DENSEST COLUMN = 6
0THE DENSITY OF THIS MATRIX IS 100.00 PERCENT.
^^^FLUID MASS IN THE BASIC X DIRECTION IS 3.342353E-02
^^^FLUID MASS IN THE BASIC Y DIRECTION IS 6.956879E-02
^^^FLUID MASS IN THE BASIC Z DIRECTION IS 4.606164E-02
^^^WRITING FLUID MASS COMPONENTS TO OP2 FILE FOR FAST HYDRO METHOD
    
```

Figure 4-34. Mass property output for motorcycle tank example.

The output of the _FLM run is an OUTPUT2 file (fast_flm.ou2) with the PKLL and AGL matrices for input into the coupled modes run.

4.2.5. Coupled Hydroelastic Model

HYDRO also creates a template for the structural coupling (CPL) run. The template as output by HYDRO is illustrated in Figure 4-35.

```

$
ASSIGN MASTER='system.master',DELETE
ASSIGN DBALL ='system.dball',DELETE
$
$ output2 file from FLM job with method=no_slosh_fast
ASSIGN INPUTT2='fast_flm.ou2' UNIT=11
$
ID      HYDRO,COUPLED
SOL     103
DIAG    8 $      Print matrix trailers
$
HYDRO writes the hydro_cpl.v2001 DMAP alter here
$
CEND
TITLE = HYDRO COUPLED SOLUTION
SUBTITLE = NO_SLOSH_FAST OPTION
$
ECHO = NONE $ Do not echo the bulk data deck
$
DISP(PLOT) = ALL      $ Recover mode shapes
$
SPC          = 1
METHOD       = 100
WEIGHTCHECK = YES
$
BEGIN BULK
$
$  PARAMETERS
$
PARAM      WTMASS 0.00259
PARAM      POST   -2
PARAM      GRDPNT 0
$
$ method for system modes
EIGRL      100          100.
$
$ placeholder for structural model bulk data
INCLUDE 'structure.blk'
$
$ Bulk data for CMS
$
PARAM      METHCMRS 250
$          sid      f1      f2      nd
EIGRL      250
SPOINT     99001    THRU   99250
QSET1      0        99001    THRU   99250
$
ENDDATA

```

Figure 4-35. Structure coupling run written by HYDRO.

For this example, the structural model is saved in a NASTRAN bulk data file called `structure.blk`, so there is no need to edit this field. The structural model includes all nodes and elements of the structure, of which a subset are the nodes wetted by the fluid. In this case, the structure model also included a “large mass,” since this was used to excite the model with an input acceleration. The fluid is connected to the correct DOF on the structure because the area matrix (AGP) is stored in DMIG format. In this case, the following changes were made to the deck:

1. The system mode database is placed on a local (S:) drive.
2. All six DOF on seismic mass node (31501) are placed in the BSET.
3. The SPC=1 card is removed from Case Control because it isn't used.
4. PARAM,WTMASS was removed because this model is in mass units.
5. The frequency range for the EIGRL,100 card is increased to 250 Hz.

The edited deck is illustrated in Figure 4-36.

```

$
ASSIGN MASTER='S:\system.master',DELETE
ASSIGN DBALL='S:\system.dball',DELETE
$
$ output2 file from FLM job with method=no_slosh_fast
ASSIGN INPUTT2='fast_flm.ou2' UNIT=11
$
ID      HYDRO,COUPLED
SOL     103
DIAG    8 $      Print matrix trailers
$
HYDRO writes the hydro_cpl.v2001 DMAP alter here
$
CEND
TITLE = HYDRO COUPLED SOLUTION
SUBTITLE = NO_SLOSH_FAST OPTION
$
ECHO = NONE $ Do not echo the bulk data deck
$
DISP(PLOT) = ALL      $ Recover mode shapes
$
METHOD      = 100
WEIGHTCHECK = YES
$
BEGIN BULK
$
$  PARAMETERS
$
PARAM      WTMASS 0.00259
PARAM      POST   -2
PARAM      GRDPNT 0
$
$ method for system modes
EIGRL      100      250.
$
$ placeholder for structural model bulk data
INCLUDE 'structure.blk'
$
$ Bulk data for CMS
$
PARAM      METHCMRS 250
$          sid      f1      f2      nd
EIGRL      250
SPOINT     99001    THRU   99250
QSET1      0        99001    THRU   99250
BSET1      123456   31501
$
ENDDATA

```

Figure 4-36. Structure coupling run after editing.

NASTRAN calculates two sets of modes. The first set is the first 250 modes without fluid mass. These frequencies are presented in Table 4-7. The first mode is at 78 Hz, followed by one at 300 Hz. The 250th mode is over 3,000 Hz, well above the frequency range of interest. However, the calculation of 250 modes without fluid mass is very fast and increases the accuracy of the final solution.

Table 4-7. Frequencies of 250 tank modes without fluid.

# 1-25	# 26-50	# 51-75	# 76-100	# 101-125	# 126-150	# 151-175	# 176-200	# 201-225	# 226-250
78.04	833.50	1192.64	1470.57	1761.83	2028.70	2264.23	2478.25	2716.12	2935.84
299.64	844.58	1196.51	1482.01	1767.79	2038.64	2275.24	2491.20	2729.74	2941.11
332.00	861.42	1212.77	1496.44	1780.31	2050.78	2288.16	2509.72	2732.84	2951.03
387.08	889.05	1230.52	1513.32	1791.59	2055.03	2300.11	2527.33	2742.65	2961.24
391.06	906.38	1236.80	1522.75	1831.88	2079.45	2303.76	2531.38	2744.90	2974.07
405.26	917.53	1241.19	1540.32	1833.84	2084.60	2317.63	2540.45	2764.42	2976.75
414.75	923.46	1252.00	1546.09	1835.68	2097.58	2336.31	2543.70	2774.20	2981.21
440.95	929.61	1267.31	1560.38	1845.91	2099.47	2346.91	2558.18	2781.94	2988.35
490.74	941.85	1279.81	1576.97	1859.10	2107.34	2354.52	2572.56	2786.82	2993.12
523.43	979.29	1304.07	1605.10	1870.26	2118.37	2357.71	2579.88	2795.60	2994.23
567.59	984.33	1310.52	1613.42	1887.90	2129.44	2368.24	2594.74	2801.04	3005.59
584.42	993.56	1328.91	1623.30	1892.60	2136.03	2382.82	2606.50	2805.44	3009.49
618.39	1000.61	1337.87	1634.70	1899.02	2159.31	2388.09	2623.27	2820.79	3014.59
624.11	1016.73	1358.07	1640.14	1911.41	2170.01	2400.42	2628.44	2835.54	3017.11
629.83	1030.15	1362.52	1653.32	1917.54	2174.22	2405.23	2632.72	2844.00	3026.31
636.14	1043.07	1371.18	1660.65	1923.50	2182.45	2411.00	2652.50	2848.81	3032.18
649.81	1065.43	1382.70	1671.90	1933.95	2200.20	2416.12	2656.72	2856.90	3034.40
661.64	1081.68	1394.71	1685.44	1958.10	2205.40	2426.55	2664.97	2863.47	3045.30
670.82	1097.36	1398.73	1695.77	1962.53	2209.74	2434.96	2670.56	2868.10	3053.48
695.01	1116.22	1415.94	1708.73	1970.50	2225.11	2439.07	2676.52	2887.28	3055.69
751.96	1117.90	1422.64	1714.59	1977.23	2234.75	2441.66	2686.37	2897.82	3066.26
771.90	1133.46	1438.76	1722.61	1991.38	2236.14	2454.15	2694.95	2903.12	3071.72
787.16	1140.20	1446.18	1733.22	2002.32	2242.78	2461.61	2702.94	2915.65	3087.19
808.98	1155.85	1448.10	1745.12	2015.39	2249.33	2464.79	2710.45	2922.88	3094.26
823.44	1166.56	1464.44	1750.22	2024.16	2262.88	2470.82	2712.59	2925.72	3107.31

After calculating modes without the fluid, the code imports the fluid matrices from the previous HYDRO runs and calculates the fluid mass. The output is listed in Figure 4-37¹⁶. The mass matrix is identical to that listed in the FLM run, though NASTRAN reverses the X and Y masses when listing the mass. This is because it is transforming the system to “principal mass” directions. The actual directions of the mass properties can be seen by examining the first three diagonal elements of the mass matrix.

¹⁶ The fluid properties are only written in Grid Point Weight Generator format if a BSET is included in the run. If not, they are written in matrix format as in Figure 4-19.

O U T P U T F R O M G R I D P O I N T W E I G H T G E N E R A T O R						
REFERENCE POINT = 0						
M O						
* 3.342353E-02	-4.507408E-06	1.711373E-04	2.315744E-03	-7.192718E-03	-6.720948E-01	*
* -4.507408E-06	6.956879E-02	9.244342E-07	7.347360E-03	-3.339222E-05	1.462014E+00	*
* 1.711373E-04	9.244342E-07	4.606164E-02	8.420973E-01	-1.000327E+00	-8.126191E-04	*
* 2.315744E-03	7.347360E-03	8.420973E-01	1.647192E+01	-1.816632E+01	1.326114E-01	*
* -7.192718E-03	-3.339222E-05	-1.000327E+00	-1.816632E+01	2.280418E+01	1.100272E-01	*
* -6.720948E-01	1.462014E+00	-8.126191E-04	1.326114E-01	1.100272E-01	4.575937E+01	*
S						
	* 1.250179E-04	9.999083E-01	1.353765E-02	*		
	* -1.000000E+00	1.250294E-04	0.000000E+00	*		
	* -1.692604E-06	-1.353764E-02	9.999084E-01	*		
DIRECTION						
MASS AXIS SYSTEM (S)	MASS	X-C.G.	Y-C.G.	Z-C.G.		
X	6.956879E-02	-4.690336E-04	2.101609E+01	1.788956E-01		
Y	3.342121E-02	-2.010402E+01	3.944988E-04	1.899992E-01		
Z	4.606396E-02	-1.827857E+01	2.171845E+01	3.232848E-02		
I (S)						
	* 1.079558E+00	1.212184E-01	-8.218560E-03	*		
	* 1.212184E-01	1.076675E+00	2.344169E-03	*		
	* -8.218560E-03	2.344169E-03	1.522825E+00	*		
I (Q)						
	* 1.199170E+00			*		
		9.568596E-01		*		
			1.523028E+00	*		
Q						
	* 7.108311E-01	7.030321E-01	2.156421E-02	*		
	* -7.029818E-01	7.111211E-01	-1.110768E-02	*		
	* -2.314381E-02	-7.263563E-03	9.997057E-01	*		

Figure 4-37. Fluid mass properties from structure coupling run.

The frequencies of the coupled modes of vibration below 250 Hz are listed in Table 4-8. The first six modes are rigid body modes because the tank is attached to a “large mass” in order to enforce acceleration inputs. The first flexible mode, illustrated in Figure 4-38, is a lateral bending mode of the tank on its brackets. This mode has shifted from 78.0 Hz without fuel to 55.6 Hz with fuel. The second flexible mode, illustrated in Figure 4-39, is a local mode of the top rear surface of the tank. This has shifted from 299.6 Hz without fuel to 149.4 Hz with fuel.

Table 4-8. Frequencies of tank modes below 250 Hz with fluid mass.

Mode	Freq (Hz)
1	0.000
2	0.000
3	0.000
4	0.000
5	0.000
6	0.000
7	55.625
8	149.388
9	190.082
10	207.222
11	218.837

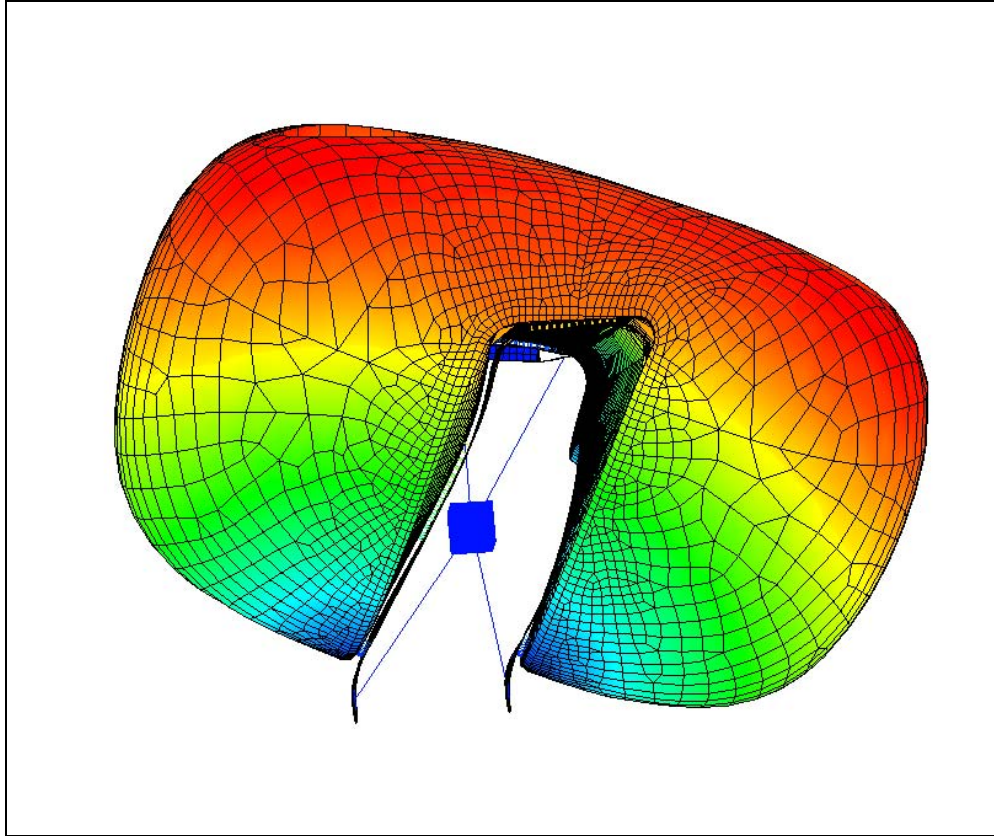

Figure 4-38. First flexible coupled mode for motorcycle tank.

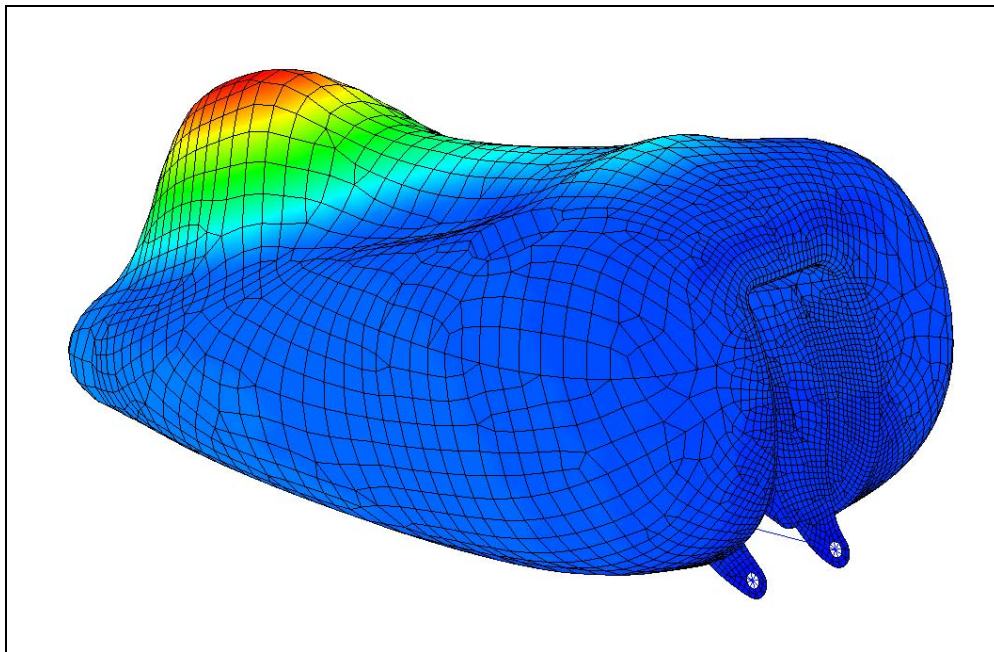

Figure 4-39. First flexible coupled mode for motorcycle tank.

5. **ACCURACY CHECKS**

This chapter discusses several accuracy checks which should be performed to verify that the fluid model has been accurately defined. Accuracy checks include the following important areas:

- Fluid mesh considerations for accurate fluid properties
- Coordinate systems
- Coincident node check
- Element quality check
- Mass property check
- Proper execution of the NASTRAN runs to create the fluid superelement
- Correct coupling of the fluid superelement and structural model

5.1. **Fluid Mesh Refinement**

The mesh refinement for the fluid model depends on the number of accurate slosh modes required. For many applications, most of the lateral effective mass is in the first lateral slosh mode pair. However, situations requiring high accuracy will probably require additional slosh modes.

A study was performed using the Titan IV/Centaur modal survey test configuration shown in Figure 5-1. For the modal survey test, the liquid oxygen tank was mostly filled with water. Analytic studies were performed to determine the mesh refinement needed to accurately obtain various lateral and axial slosh modes. Four meshes were analyzed in NASTRAN. The number of elements across the free surface was varied from a coarse value of eight elements to a fine value of twenty elements. The results are plotted in Figure 5-2 as frequency ratios relative to the results of the twenty-element mesh. The modal frequencies and errors relative to the solution with twenty-element mesh are listed in Table 5-1.

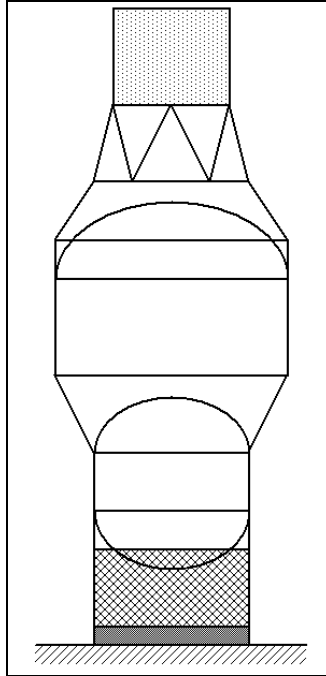

Figure 5-1. Titan/Centaur modal survey configuration.

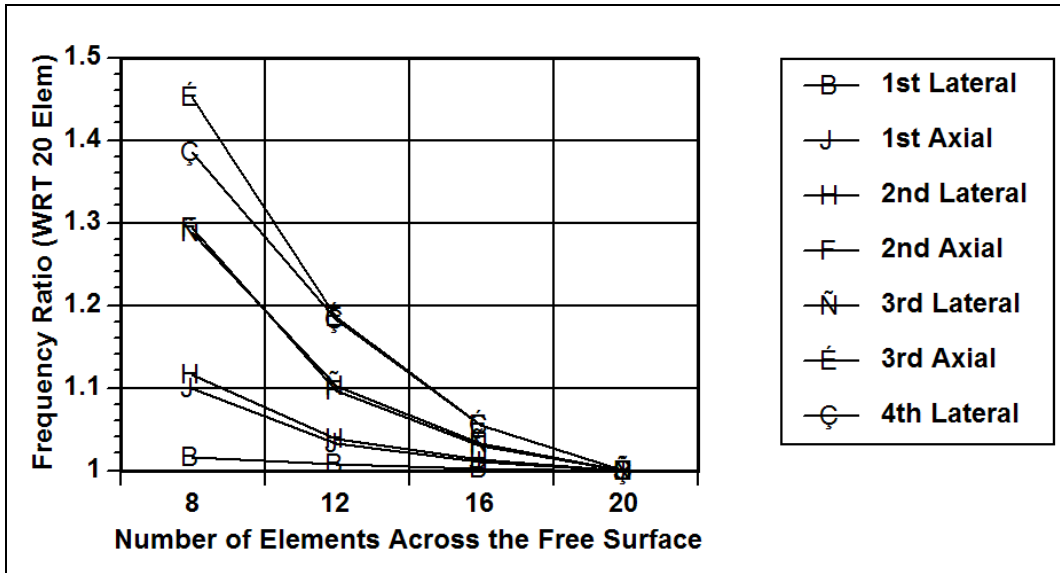

Figure 5-2. At least sixteen elements across the free surface were required to obtain 5% accuracy on the third lateral slosh mode for the Titan IV Centaur modal survey test configuration.

Table 5-1. Slosh mode frequencies for the Titan IV Centaur modal survey test configuration for several fluid mesh refinements.

Mode	8		12		16		20
	Freq (Hz)	Error	Freq (Hz)	Error	Freq (Hz)	Error	Freq (Hz)
1st Lateral	0.676	1.5%	0.670	0.6%	0.667	0.2%	0.666
1st Axial	1.011	9.9%	0.949	3.2%	0.928	0.9%	0.920
2nd Lateral	1.224	11.6%	1.139	3.8%	1.111	1.3%	1.097
2nd Axial	1.674	29.4%	1.420	9.7%	1.331	2.9%	1.294
3rd Lateral	1.864	28.9%	1.593	10.2%	1.491	3.1%	1.446
3rd Axial	2.411	45.2%	1.970	18.6%	1.752	5.5%	1.661
4th Lateral	2.497	38.4%	2.131	18.1%	1.901	5.4%	1.804
4th Axial			2.624	27.3%	2.231	8.2%	2.061
5th Lateral			2.747	24.9%	2.370	7.8%	2.199
5th Axial			3.128	24.6%	2.775	10.6%	2.510
6th Lateral			3.160	19.7%	2.894	9.6%	2.641

A second study was performed using the example problem described in Chapter 4. Using the same geometry, a second hydroelastic finite element model was developed which had a finer fluid mesh, as shown in Figure 5-3. The fine mesh model was analyzed using the HYDRO procedures in NASTRAN. Results are compared with theoretical results obtained from [7] in Table 5-2. As expected, the fine model had much better agreement with theory than did the coarse model.

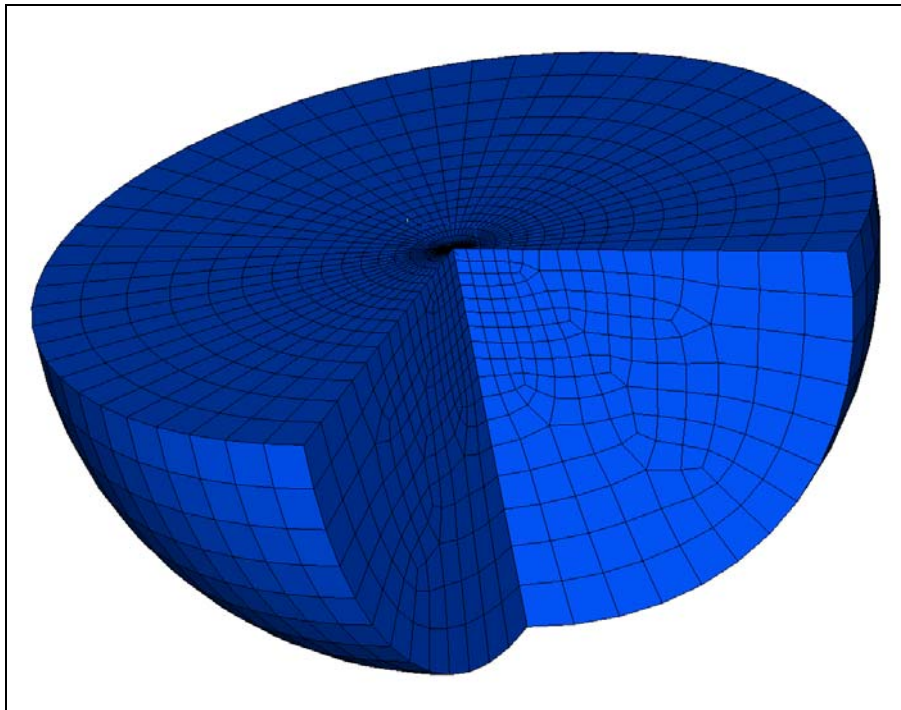

Figure 5-3. Fine mesh representation of hemisphere example problem.

Table 5-2. Slosh mode frequencies for the hemisphere with coarse and fine meshes.

Description	Theory	Coarse		Fine	
		HYDR O	Error	HYDR O	Error
1st Lateral	0.504	0.506	0.4%	0.504	0.1%
1st Axial	0.782	0.797	2.0%	0.785	0.4%
2nd Lateral	0.928	0.964	3.8%	0.934	0.7%
2nd Axial	1.067	1.144	7.2%	1.079	1.2%
3rd Lateral	1.178	1.304	10.7%	1.199	1.8%
3rd Axial	1.287	1.492	15.9%	1.342	4.2%
4th Lateral	1.381	1.602	16.0%	1.428	3.4%

The results of the two studies show that the frequency of the first lateral slosh mode can be accurately obtained with a coarse mesh. However, if the higher slosh modes are important, additional elements are needed to obtain accurate results. For the Centaur example, sixteen elements across the free surface diameter were needed to calculate the frequency of the third slosh mode to 5% accuracy (relative to a twenty-element solution). For the hemisphere problem, 24 elements across the free surface provided accuracy within 8% for the third lateral slosh mode.

A general rule is to use eight elements across the free surface per slosh mode desired. This will provide good accuracy but may require a very fine mesh if higher slosh modes are necessary. Less refined models may provide acceptable results depending on the skill of the modeler and engineering judgment.

If possible, the fluid mesh should be more refined near the free surface and less refined at the bottom of the fluid (assuming that the fluid depth/width ratio is greater than one). For “deep” tanks, most of the slosh behavior is near the surface, while the fluid at the bottom of the tank is nearly stationary. Appropriate gradients of the mesh refinement will result in accurate slosh modes without an excessively fine fluid model.

5.2. Coordinate Systems

The special requirements for coordinate systems are reviewed below:

- The definition coordinate system for the fluid, wetted structure, and free surface nodes must be the same.
- The displacement coordinate systems for the coincident fluid, wetted structure, and free surface nodes must be the same at each location but may vary throughout the model. For example, the nodes on the axis of a cylindrical system should use the basic displacement system, while other nodes could use a cylindrical displacement coordinate system.

- The coincident fluid/structure and fluid/free surface nodes must be exactly coincident as expressed in the definition coordinate system. The coincidence check performed by the HYDRO program uses the local coordinates as defined in I–deas (no transformation performed to a global or basic system).

Nodes which are on the centerline Z axis of a cylindrical coordinate system should **not** use that cylindrical coordinate system as the nodes' displacement coordinate system. The radial and tangential directions are not defined for a node located on the axis of a cylindrical coordinate system. Nodes which are on the centerline Z axis of a cylindrical coordinate system should use a rectangular coordinate system as the nodes' displacement coordinate system.

5.3. **Coincident Node Check**

A coincident node check can be performed in I–deas for the HFEM. The check should properly list the coincident pressure/wetted structure and pressure/free surface nodes. The coincident nodes must **not** be merged by I–deas.

5.4. **Element Quality Checks**

A variety of element quality checks can be performed in I–deas including:

- Free edge
- Coincident elements
- Warping
- Interior angle
- Distortion

The free edge check is especially useful for checking the HFEM. This check should be performed on the fluid, wetted structure, and free surface elements as individual groups. The free edge check should present correct results, as shown in Figure 5-4. The free edge check in FEMAP is performed by choosing a "Free Edge" model style on the View Select form.

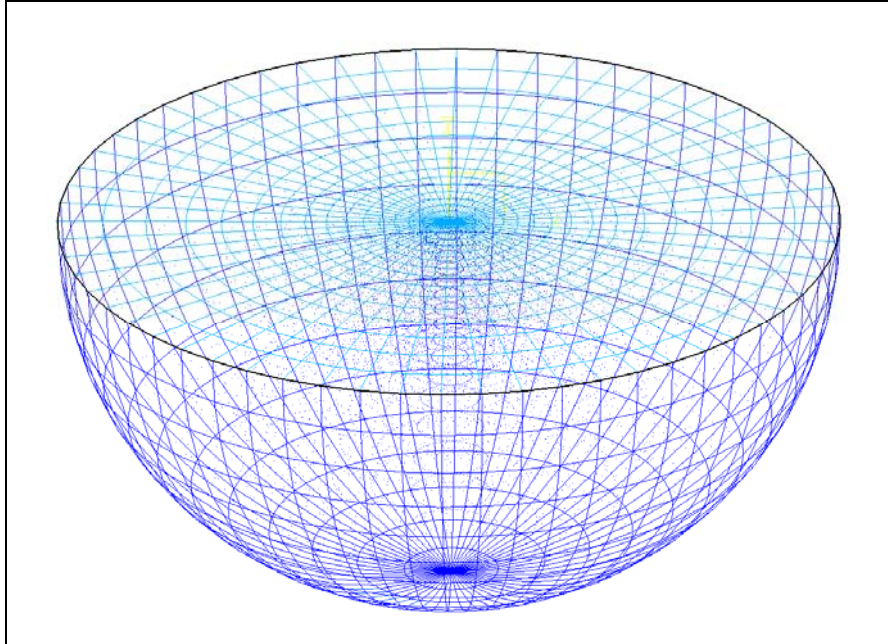

Figure 5-4. Free edge check can identify errors in the HYDRO FEM.

The element warping and distortion checks should indicate no improperly formed elements. A coincident element check should indicate no coincident elements.

5.5. Shell Element Normals

The normal direction of the shell elements for the wetted structure and free surface must all point **outward**. If there is any inconsistency in the shell element orientation (some of the shells point inward while other point outward), the fluid mass matrix will be incorrect along one or more of the basic coordinate system axes as reported by the NASTRAN Grid Point Weight Generator. If the shell element normals point uniformly inward, the fluid mass properties will be correct, but the sign of the fluid stiffness matrix will be incorrect (negative terms on the diagonal of the gravity stiffness matrix).

The orientation of the shell element normals can be easily checked in I-deas by defining a unit pressure load on the wetted structure and free surface shell elements. The I-deas graphic display, such as that shown previously in Figure 4-4, should be checked carefully to verify that all pressure vectors point outward. In FEMAP, the shell element normal display is activated by turning on Normal Vectors for Element-Directions on the View Options form as illustrated in Figure 5-5.

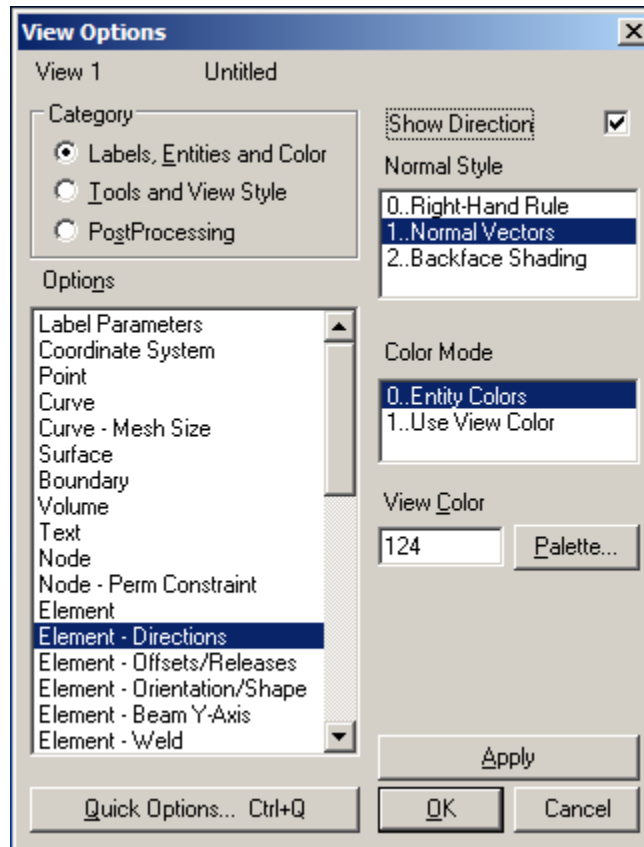

Figure 5-5. Element normal vector display is selected on the View Options form in FEMAP.

5.6. **Fluid Mass Check**

The mass of the fluid elements should be checked in I–deas. The material table must be modified to have the correct mass density.

The mass calculated by NASTRAN in the FLM and SUP runs should agree very closely with the I–deas value (within 1%). In addition, the NASTRAN mass calculation should be checked to make sure that the mass values in the X, Y, and Z axes are essentially identical (within 1%)¹⁷. There may be a slight difference between the mass values along each axis because of the accuracy of the area matrices generated by quadrilateral and triangular shell elements. However, if there is significant variation in the mass values, this indicates errors in the wetted structure and/or free surface shell elements. The most likely error is inconsistent shell element normals (some pointed inward while others pointed outward). Another possibility is improper definition of the free surface (improper free edges or all free surface elements not using the same property ID).

¹⁷ For the NO_SLOSH options, only the mass properties normal to the free surface will be equal to the total fluid mass. The mass properties in the plane of the fluid surface will be less.

REFERENCES

1. Craig, R.R., and Bampton, M.C.C., "Coupling of Substructures for Dynamic Analysis," AIAA Journal, Vol. 6, No. 7, July 1968.
2. Final Report, "NASTRAN Hydroelastic Modal Studies, Volume 1, Introduction, Theory, and Results," Universal Analytics, Inc., NASA-CR-150393, May 1977.
3. Zienkiewics, O.C., The Finite Element Method in Engineering Science, pp. 240–247, McGraw–Hill, New York, 1971.
4. Coppolino, R.N., "A Numerically Efficient Finite Element Hydroelastic Analysis," Volume 1: Theory and Results, NASA CR-2662, April 1976.
5. Guyan, R.J., "Reduction of Stiffness and Mass Matrices," AIAA Journal, Vol. 3, No. 2, February 1965.
6. Bodley, C.S., Demchak, L.J., and Pawlowski, S.W., "Dynamic Analysis and Test of a Fluid Loaded Propellant Tank," AIAA 85-0631-CP, 26th Structures, Structural Dynamics, and Materials Conference, 1985.
7. McIver, P., "Sloshing Frequencies for Cylindrical and Spherical Containers Filled to an Arbitrary Depth," Journal of Fluid Mechanics (Great Britain), 1989, Vol. 201, pp 243-257.
8. Blevins, Robert D., Formulas for Natural Frequency and Mode Shape, Van Nostrand Reinhold Company, New York, NY, 1979.

Appendix A

New Features and Enhancements in HYDRO Version 2

ATA HYDRO Version 2 has the following new features and enhancements:

- Hydroelastic models can be processed using MSC.NASTRAN Versions 66A and 67 as well as Version 65.
- For MSC/NASTRAN Versions 66A and 67, the user enters the database names for the pressure model and the superelement model. The file management section (FMS) commands are written by HYDRO to the NASTRAN decks.
- Multiple finite element models may be in the SDRC I-deas universal file. The user is prompted to select the finite element model which is the hydroelastic finite element model (HFEM).
- SDRC I-deas default coordinate systems 1 (cylindrical) and 2 (spherical) are automatically written to the MSC/NASTRAN bulk data deck.
- In the HYDRO “MPC” run, the user specifies a minimum significant MPC coefficient. Degrees of freedom whose MPC coefficients are less than the user-specified value are assumed negligible and are eliminated from the MPC equation.
- In the HYDRO “MPC” run, default values are no longer available for the dependent grid and DOF. The previous default was simply the first grid and DOF printed by MSC/NASTRAN. This was not necessarily a good selection. Therefore, a default value is no longer provided by HYDRO, and the dependent grid and DOF must be entered by the user.

Appendix B

New Features and Enhancements in HYDRO Version 3

ATA HYDRO Version 3 is a complete rewrite of HYDRO. This version can be executed from the command line by typing “hydro -t” or through a GUI by typing “hydro”. In addition, the following changes have been made.

- The DMAP is no longer contained in the code but is stored in the HYDRO executable directory. This makes it much easier to generate versions of HYDRO for future versions of either MSC or NX Nastran. To add any new version of DMAP, the following five files should be added to the HYDRO executable directory:

hydro_flk.xxx

hydro_flm.xxx

hydro_fsk.xxx

hydro_sup.xxx

hydro_cpl.xxx

where .xxx refers to the NASTRAN version (v2006, nx5, etc.). The code will find all available versions, so no updates of the HYDRO code will be required to support future versions of NASTRAN. HYDRO version 3 is initially delivered with support for MSC Nastran V2004 and V2005 and NX Nastran NXN3 and NXN4. An “_” reflects a “.” in the version, so to include NXN V6.1 the filetype for the alters should be .nxn6_1.

- All size limitations have now been removed from the code. The only limitation on the size model that can be handled is the amount of memory available.
- Any bulk format can be read (free field, narrow, wide, include files, replication cards)
- Nodes no longer need to be defined in the same definition coordinate system since the code transforms these internally to the basic Cartesian system.
- Tolerance for coincident node check can be set by user (previously 0.1) and is applied to the basic Cartesian coordinates. The default is now 0.01.
- The code is considerably faster for large models.
- GRID cards written to new input files with their original X ,Y, and Z definitions (not F8.3) to preserve all original significant digits, whether narrow field or wide field.
- MPC coefficients are read from the .pch file, rather than the .f06 file, in order to make the process more stable across multiple NASTRAN versions.
- Capability to read model data from Universal files has been eliminated. The only input format is NASTRAN.
- HYDRO now supports a "fast" option that doesn't assemble the full fluid mass matrix. This option writes out components of the fluid mass matrix in OUTPUT2 format for input into the structural modes run. This method allows “no-slosh” HYDRO fluid representations to be included in large stress models.

HYDRO now writes a template for the deck to couple the structural and fluid models.

Appendix C

New Features and Enhancements in HYDRO Version 4

ATA HYDRO Version 4 includes the options for external superelement processing that is available in NX NASTRAN version 6.0 and higher and MSC.NASTRAN version 2004 and higher. The external superelement option can be accessed by the GUI as shown in Figure 5-6.

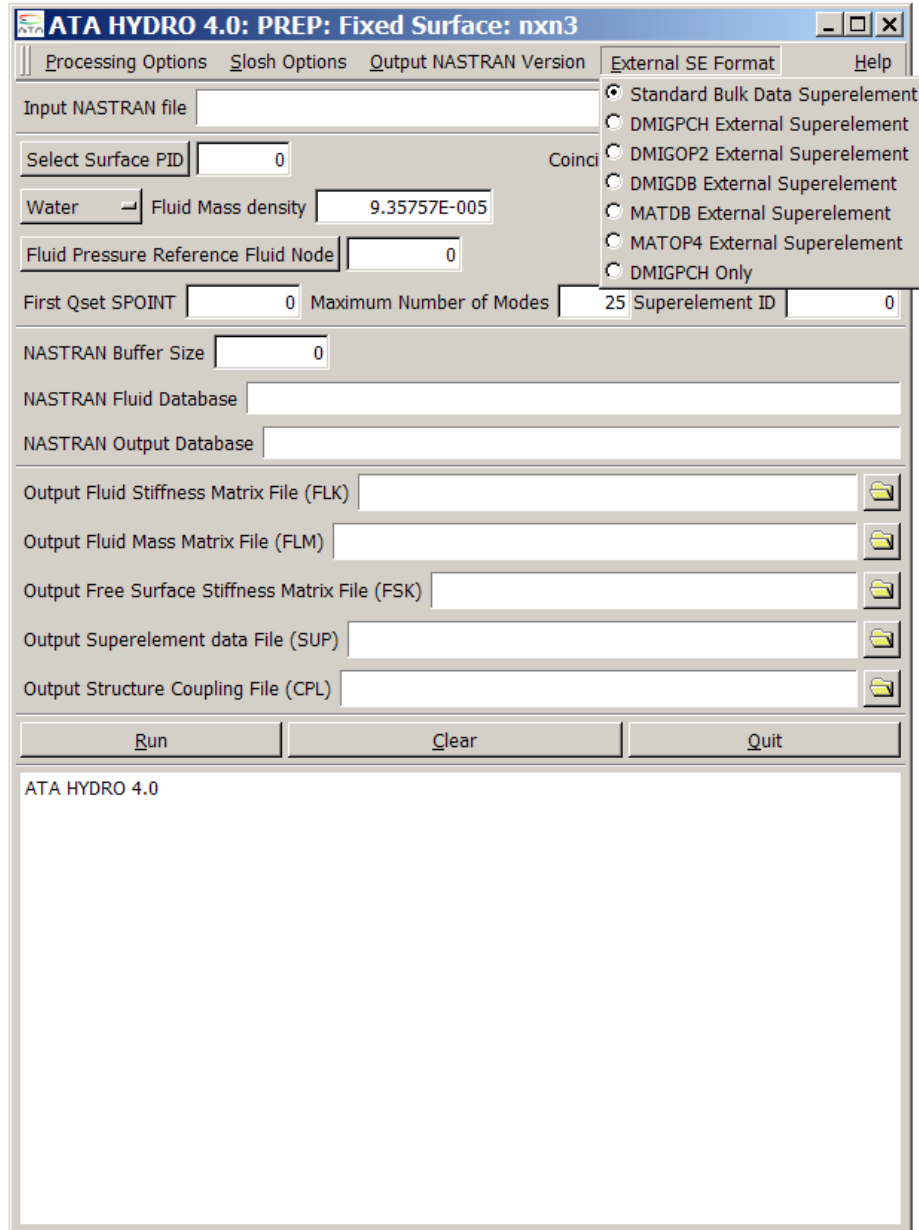

Figure 5-6. External superelement options.

The external superelement options are shown below:

Standard Bulk Data Superelement
DMIGPCH External Superelement

DMIGOP2 External Superelement
DMIGDB External Superelement
MATDB External Superelement
MATOP4 External Superelement
DMIGPCH Only

Choosing any of the external superelement options will write the appropriate SUP file, the corresponding CPL file and a .asm file to include in the CPL run.

Some minor modifications to the code include:

1. SPOINTs rather than GRIDs are used to store modal DOF. This can be changed by editing the SUP and CPL files if necessary.
2. A number of slosh modes rather than a cutoff frequency is specified. The default value is 25.