

# Thermal and Structural Design of a Low-Profile Dual-Band Antenna

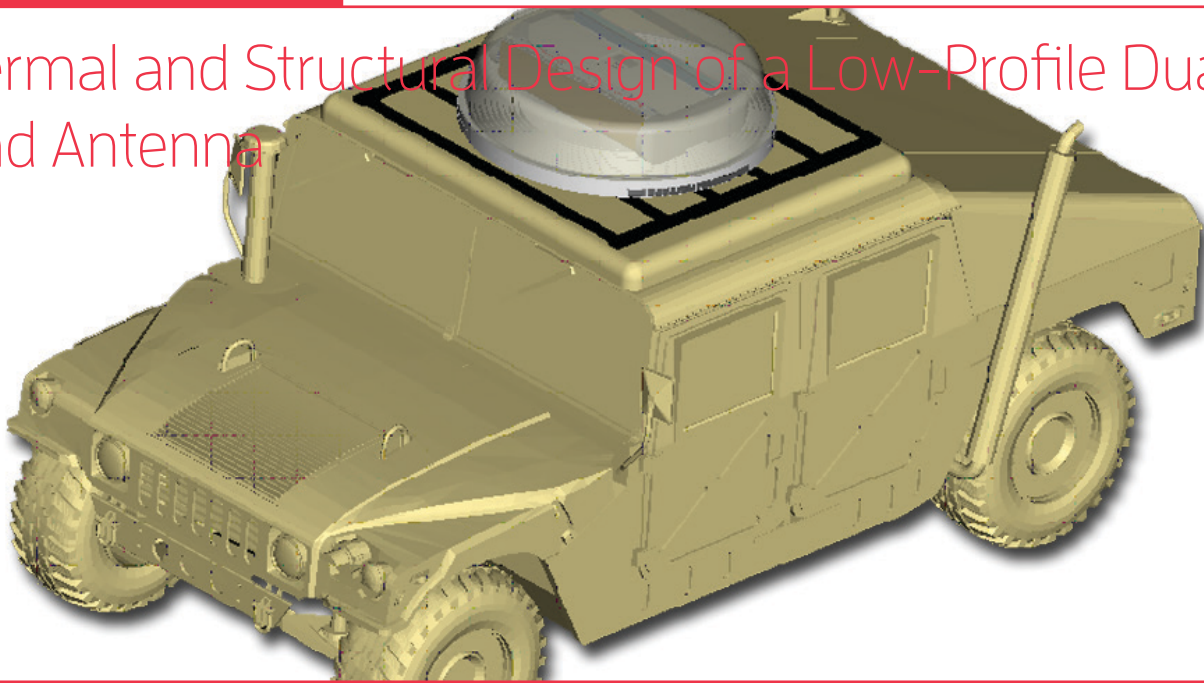

## Case Study

### OVERVIEW

ThinKom Solutions, Inc., a provider of compact antenna solutions for aeronautical, on-the-move, and portable applications, contracted ATA to provide design and analysis support for a compact dual-band antenna system. The X/Ka-band antenna system mounts on the roof exterior of a military ground vehicle. The system is subjected to the dynamic environments of the vehicle, including vibration, shock, and thermal excursions. Because the electronics for the system are completely self-contained under a radome, an integrated cooling system is required to ensure that components do not exceed allowable operating temperatures. Multiple thermal management strategies were utilized to meet stringent performance requirements and give ThinKom's design a competitive edge.

### TASKS PERFORMED & KEY OUTCOMES

- Applied thermal principles to size cooling channels and select fans.
- Used a detailed thermal/fluid model of the antenna to investigate best placement of hot components and fans and complete detailed design of structures in the conduction path.
- Using analysis, enhanced the cooling design with thermoelectric coolers to meet the stringent temperature requirements of select components.
- Performed thermal distortion analysis to ensure no interference at rotating interfaces.
- Used finite element analysis to validate performance in prescribed dynamic environments.

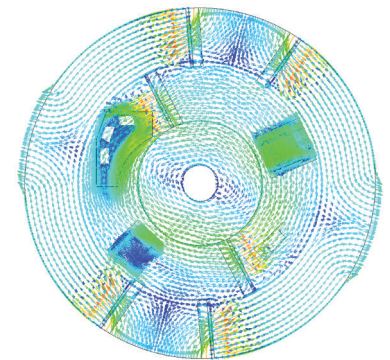

Flow vectors from fluid/thermal simulation used to aid design of electronics cooling system

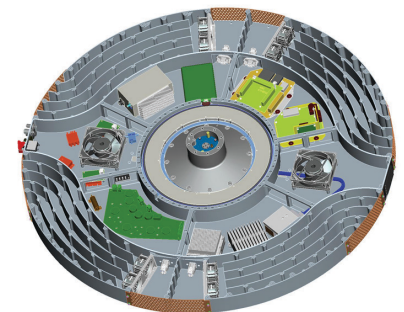

CAD geometry of SATCOM electronics compartment